



Your **definitive** source
for quality pre-owned
equipment.

Artisan Technology Group

(217) 352-9330 | sales@artisanTG.com | artisanTG.com

Full-service, independent repair center
with experienced engineers and technicians on staff.

We buy your excess, underutilized, and idle equipment
along with credit for buybacks and trade-ins.

Custom engineering
so your equipment works exactly as you specify.

- Critical and expedited services
- In stock / Ready-to-ship
- Leasing / Rentals / Demos
- ITAR-certified secure asset solutions

Expert team | Trust guarantee | 100% satisfaction

All trademarks, brand names, and brands appearing herein are the property of their respective owners.

Find the *National Instruments GPIB-140* at our website: **Click *HERE***

GPIB-140

User Manual

June 1995 Edition

Part Number 320911B-01

**© Copyright 1995 National Instruments Corporation.
All Rights Reserved.**

National Instruments Corporate Headquarters

6504 Bridge Point Parkway

Austin, TX 78730-5039

(512) 794-0100

Technical support fax: (800) 328-2203

(512) 794-5678

Branch Offices:

Australia 03 9 879 9422, Austria 0662 45 79 90 0, Belgium 02 757 00 20,

Canada (Ontario) 519 622 9310, Canada (Québec) 514 694 8521,

Denmark 45 76 26 00, Finland 90 527 2321, France 1 48 14 24 24,

Germany 089 741 31 30, Hong Kong 2645 3186, Italy 02 48301892,

Japan 03 5472 2970, Korea 02 596 7456, Mexico 5 202 2544,

Netherlands 03480 33466, Norway 32 84 84 00, Singapore 2265886,

Spain 91 640 0085, Sweden 08 730 49 70, Switzerland 056 20 51 51,

Taiwan 02 377 1200, U.K. 01635 523545

Limited Warranty

The GPIB-140 and GPIB-140/2 are warranted against defects in materials and workmanship for a period of two years from the date of shipment, as evidenced by receipts or other documentation. National Instruments will, at its option, repair or replace equipment that proves to be defective during the warranty period. This warranty includes parts and labor.

A Return Material Authorization (RMA) number must be obtained from the factory and clearly marked on the outside of the package before any equipment will be accepted for warranty work. National Instruments will pay the shipping costs of returning to the owner parts which are covered by warranty.

National Instruments believes that the information in this manual is accurate. The document has been carefully reviewed for technical accuracy. In the event that technical or typographical errors exist, National Instruments reserves the right to make changes to subsequent editions of this document without prior notice to holders of this edition. The reader should consult National Instruments if errors are suspected. In no event shall National Instruments be liable for any damages arising out of or related to this document or the information contained in it.

EXCEPT AS SPECIFIED HEREIN, NATIONAL INSTRUMENTS MAKES NO WARRANTIES, EXPRESS OR IMPLIED, AND SPECIFICALLY DISCLAIMS ANY WARRANTY OF MERCHANTABILITY OR FITNESS FOR A PARTICULAR PURPOSE. CUSTOMER'S RIGHT TO RECOVER DAMAGES CAUSED BY FAULT OR NEGLIGENCE ON THE PART OF NATIONAL INSTRUMENTS SHALL BE LIMITED TO THE AMOUNT THEREFORE PAID BY THE CUSTOMER. NATIONAL INSTRUMENTS WILL NOT BE LIABLE FOR DAMAGES RESULTING FROM LOSS OF DATA, PROFITS, USE OF PRODUCTS, OR INCIDENTAL OR CONSEQUENTIAL DAMAGES, EVEN IF ADVISED OF THE POSSIBILITY THEREOF. This limitation of the liability of National Instruments will apply regardless of the form of action, whether in contract or tort, including negligence. Any action against National Instruments must be brought within one year after the cause of action accrues. National Instruments shall not be liable for any delay in performance due to causes beyond its reasonable control. The warranty provided herein does not cover damages, defects, malfunctions, or service failures caused by owner's failure to follow the National Instruments installation, operation, or maintenance instructions; owner's modification of the product; owner's abuse, misuse, or negligent acts; and power failure or surges, fire, flood, accident, actions of third parties, or other events outside reasonable control.

Copyright

Under the copyright laws, this publication may not be reproduced or transmitted in any form, electronic or mechanical, including photocopying, recording, storing in an information retrieval system, or translating, in whole or in part, without the prior written consent of National Instruments Corporation.

Trademarks

Product and company names listed are trademarks or trade names of their respective companies.

WARNING REGARDING MEDICAL AND CLINICAL USE OF NATIONAL INSTRUMENTS PRODUCTS

National Instruments products are not designed with components and testing intended to ensure a level of reliability suitable for use in treatment and diagnosis of humans. Applications of National Instruments products involving medical or clinical treatment can create a potential for accidental injury caused by product failure, or by errors on the part of the user or application designer. Any use or application of National Instruments products for or involving medical or clinical treatment must be performed by properly trained and qualified medical personnel, and all traditional medical safeguards, equipment, and procedures that are appropriate in the particular situation to prevent serious injury or death should always continue to be used when National Instruments products are being used. National Instruments products are NOT intended to be a substitute for any form of established process, procedure, or equipment used to monitor or safeguard human health and safety in medical or clinical treatment.

FCC/DOC Radio Frequency Interference Compliance

This equipment generates and uses radio frequency energy and, if not installed and used in strict accordance with the instructions in this manual, may cause interference to radio and television reception. This equipment has been tested and found to comply with the following two regulatory agencies:

Federal Communications Commission

This device complies with Part 15 of the Federal Communications Commission (FCC) Rules for a Class A digital device. Operation is subject to the following two conditions:

1. This device may not cause harmful interference in commercial environments.
2. This device must accept any interference received, including interference that may cause undesired operation.

Canadian Department of Communications

This device complies with the limits for radio noise emissions from digital apparatus set out in the Radio Interference Regulations of the Canadian Department of Communications (DOC).

Le présent appareil numérique n'émet pas de bruits radioélectriques dépassant les limites applicables aux appareils numériques de classe A prescrites dans le règlement sur le brouillage radioélectrique édicté par le ministère des communications du Canada.

Instructions to Users

These regulations are designed to provide reasonable protection against harmful interference from the equipment to radio reception in commercial areas. Operation of this equipment in a residential area is likely to cause harmful interference, in which case the user will be required to correct the interference at his own expense.

There is no guarantee that interference will not occur in a particular installation. However, the chances of interference are much less if the equipment is installed and used according to this instruction manual.

If the equipment does cause interference to radio or television reception, which can be determined by turning the equipment on and off, one or more of the following suggestions may reduce or eliminate the problem.

- Operate the equipment and the receiver on different branches of your AC electrical system.

- Move the equipment away from the receiver with which it is interfering.
- Reorient or relocate the receiver's antenna.
- Be sure that the equipment is plugged into a grounded outlet and that the grounding has not been defeated with a cheater plug.

Notice to user: Changes or modifications not expressly approved by National Instruments could void the user's authority to operate the equipment under the FCC Rules.

If necessary, consult National Instruments or an experienced radio/television technician for additional suggestions. The following booklet prepared by the FCC may also be helpful: *How to Identify and Resolve Radio-TV Interference Problems*. This booklet is available from the U.S. Government Printing Office, Washington, DC 20402, Stock Number 004-000-00345-4.

Contents

About This Manual	xi
Organization of This Manual	xi
Conventions Used in This Manual	xii
Related Documentation	xiii
Customer Communication	xiii
Chapter 1	
Introduction	1-1
What Your Kit Should Contain	1-1
Optional Equipment	1-1
Hardware Description	1-2
Chapter 2	
Connection	2-1
Configure the DIP Switch	2-1
Connect the Hardware	2-1
Step 1. Connect the Cables	2-1
Step 2. Switch On Your GPIB Extender	2-2
Optional Self-Test	2-3
Chapter 3	
Configuration and Operation	3-1
Data Transfer Modes	3-1
Unbuffered Mode	3-1
Buffered Mode	3-1
Setting the Data Transfer Mode	3-1
HS488 Mode	3-2
HS488 Disabled	3-2
HS488 Enabled	3-2
Setting the HS488 Mode	3-3
Parallel Poll Response (PPR) Modes	3-3
Immediate PPR Mode	3-4
Latched PPR Mode	3-4
Choosing the PPR Mode	3-4
Setting the PPR Mode	3-5
Operating the Extension System	3-5
POWER LED	3-5
LINK LED	3-6
ERROR LED	3-6

Chapter 4

Theory of Operation	4-1
Message Interpreter Layer	4-2
Packet Translation Layer	4-3
Link Management Layer.....	4-3
Parallel-to-Serial Translation Layer.....	4-3
Physical Layer	4-3

Appendix A

Operation of the GPIB	A-1
Types of Messages	A-1
Talkers, Listeners, and Controllers	A-1
The Controller-In-Charge and System Controllers	A-2
GPIB Signals and Lines	A-2
Data Lines	A-2
Handshake Lines	A-3
Interface Management Lines	A-3
Physical and Electrical Characteristics	A-4
Configuration Requirements	A-5

Appendix B

Specifications	B-1
-----------------------------	-----

Appendix C

Introduction to HS488	C-1
Objectives of HS488	C-1
Fast Transfer Rates	C-1
Compatibility with Existing IEEE 488.1 Devices	C-1
No Additional Software Overhead—Automatic HS488 Detection... ..	C-1
No Changes to the IEEE 488.2 Standard.....	C-1
No Added Cabling Restrictions beyond IEEE 488.1	C-2
IEEE 488.1 Requirements for Higher Speed Operation (T1 Delay \geq 350 ns).....	C-2
Additional HS488 System Requirements	C-2
Sequence of Events in Data Transfers	C-2
Case 1: Talker and Listener are HS488 Capable	C-4
Case 2: Talker Is HS488 Capable, But Listener Is Not HS488 Capable	C-5
Case 3: Talker Is Not HS488 Capable, But Listener Is HS488 Capable	C-6
System Configuration	C-6

Appendix D

Multiline Interface Messages	D-1
---	-----

Appendix E	
Customer Communication	E-1
Glossary	G-1

Figures

Figure 1-1.	Typical Extension System (Physical Configuration)	1-2
Figure 1-2.	Typical Extension System (Logical Configuration)	1-2
Figure 2-1.	DIP Switch Default Setting	2-1
Figure 2-2.	GPIB Extenders with Fiber Optic Cable Connected.....	2-2
Figure 2-3.	GPIB Extender Configured for Optional Self-Test.....	2-3
Figure 3-1.	Switch Setting for Buffered Data Transfer Mode	3-2
Figure 3-2.	Switch Setting for HS488 Mode (Enabled)	3-3
Figure 3-3.	Switch Setting for Immediate Parallel Poll Response (PPR) Mode	3-5
Figure 4-1.	GPIB Extender Block Diagram.....	4-2
Figure A-1.	GPIB Connector and the Signal Assignment	A-4
Figure A-2.	Linear and Star System Configuration.....	A-5
Figure C-1.	IEEE 488.1 and HS488 Transfers	C-3
Figure C-2.	Talker and Listener are HS488 Capable	C-4
Figure C-3.	Talker is HS488 Capable, But Listener Is Not HS488 Capable	C-5
Figure C-4.	Talker is Not HS488 Capable, But Listener Is 488 Capable.....	C-6

Tables

Table A-1.	GPIB Handshake Lines	A-3
Table A-2.	GPIB Interface Management Lines.....	A-3
Table B-1.	System Configuration	B-1
Table B-2.	Performance Characteristics	B-1
Table B-3.	Operation Characteristics	B-2
Table B-4.	Electrical Characteristics.....	B-2
Table B-5.	Environmental Characteristics	B-2
Table B-6.	Physical Characteristics	B-3

About This Manual

This manual describes how to install, configure, and operate the National Instruments GPIB-140 or GPIB-140/2 bus extender.

Organization of This Manual

This manual is organized as follows:

- Chapter 1, *Introduction*, lists what your kit should contain and optional equipment you can order, and gives a brief description of the GPIB extender.
- Chapter 2, *Connection*, describes how to connect the GPIB extender and verify that it is operating properly.
- Chapter 3, *Configuration and Operation*, describes how to configure and operate a GPIB-140 or GPIB-140/2 system.
- Chapter 4, *Theory of Operation*, describes how the GPIB extender circuitry operates.
- Appendix A, *Operation of the GPIB*, describes some basic concepts you should understand to operate the GPIB. It also contains a description of the physical and electrical characteristics and the configuration requirements of the GPIB.
- Appendix B, *Specifications*, lists the specifications of the GPIB extender.
- Appendix C, *Introduction to HS488*, describes HS488 and the sequence of events in data transfers.
- Appendix D, *Multiline Interface Messages*, lists the multiline interface messages and describes the mnemonics and messages that correspond to the interface functions.
- Appendix E, *Customer Communication* contains forms you can use to request help from National Instruments or to comment on our products and manuals.
- The *Glossary* contains an alphabetical list and a description of terms used in this manual, including abbreviations, acronyms, metric prefixes, mnemonics, and symbols.

Conventions Used in This Manual

The following conventions are used in this manual.

bold	Bold text denotes light-emitting diodes (LEDs).
<i>italic</i>	Italic text denotes emphasis, a cross reference, or an introduction to a key concept.
<i>bold italic</i>	Bold italic text denotes a note, caution, or warning.
monospace	Text in this font denotes text or characters that are to be literally input from the keyboard, sections of code, programming examples, and syntax examples. This font is also used for the proper names of disk drives, directories, programs, subprograms, subroutines, device names, functions, variables, field names and filenames.
<>	Angle brackets enclose the name of a key on the keyboard—for example, <Shift>.
-	A hyphen between two or more key names enclosed in angle brackets denotes that you should simultaneously press the named keys—for example, <Control-Alt-Delete>.
GPIB-140	GPIB-140 refers to a National Instruments GPIB extender that extends the GPIB to a maximum distance of 1 km.
GPIB-140/2	GPIB-140/2 refers to a National Instruments GPIB extender that extends the GPIB to a maximum distance of 2 km.
GPIB extender	GPIB extender refers generically to either the GPIB-140 or the GPIB-140/2 in cases where the material can apply to either extender.
IEEE 488 and IEEE 488.2	IEEE 488 and IEEE 488.2 refer to the ANSI/IEEE Standard 488.1-1987 and the ANSI/IEEE Standard 488.2-1992, respectively, which define the GPIB.

Abbreviations, acronyms, metric prefixes, mnemonics, symbols, and terms are listed in the *Glossary*.

Related Documentation

The following documents contain information that you may find helpful as you read this manual.

- ANSI/IEEE Standard 488.1-1987, *IEEE Standard Digital Interface for Programmable Instrumentation*
- ANSI/IEEE Standard 488.2-1992, *IEEE Standard Codes, Formats, Protocols, and Common Commands*

Customer Communication

National Instruments wants to receive your comments on our products and manuals. We are interested in the applications you develop with our products, and we want to help if you have problems with them. To make it easy for you to contact us, this manual contains comment and configuration forms for you to complete. These forms are in Appendix E, *Customer Communication*, at the end of this manual.

Chapter 1

Introduction

This chapter lists what your kit should contain and optional equipment you can order, and gives a brief description of the GPIB extender.

What Your Kit Should Contain

Your kit should contain the following components.

- ❑ One of the following GPIB-140 or GPIB-140/2 bus extenders:
 - U.S. 100-120 VAC
 - Switzerland 220-240 VAC
 - Australia 220-240 VAC
 - Universal European 220-240 VAC
 - North American 220-240 VAC
 - U.K. 220-240 VAC

- ❑ One of the following standard 3-wire power cables:
 - 100-120 VAC
 - 220-240 VAC

Optional Equipment

You can contact National Instruments to order any of the following equipment to go with your kit.

- Transmission cable:
 - Type T7 fiber optic cable – up to 1 km (used with GPIB-140)
 - Type T8 fiber optic cable – up to 2 km (used with GPIB-140/2)

- Shielded GPIB cables*:
 - Type X1 single-shielded GPIB cables – 1 m, 2 m, or 4 m
 - Type X2 double-shielded GPIB cables – 1 m, 2 m, or 4 m

* To meet FCC emission limits for this Class A device, you must use a shielded (Type X1 or X2) GPIB cable. Operating this equipment with a non-shielded cable may cause interference to radio and television reception in commercial areas.

Hardware Description

The GPIB-140 and GPIB-140/2 are high-speed bus extenders that are used in pairs with fiber optic cable to connect two separate GPIB (IEEE 488) bus systems in a functionally transparent manner.

Although the two bus systems are physically separate, as shown in Figure 1-1, devices logically appear to be located on the same bus, as shown in Figure 1-2.

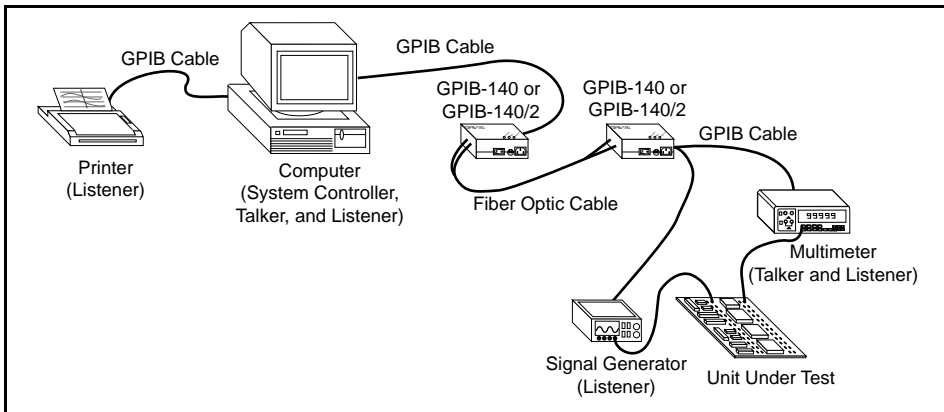

Figure 1-1. Typical Extension System (Physical Configuration)

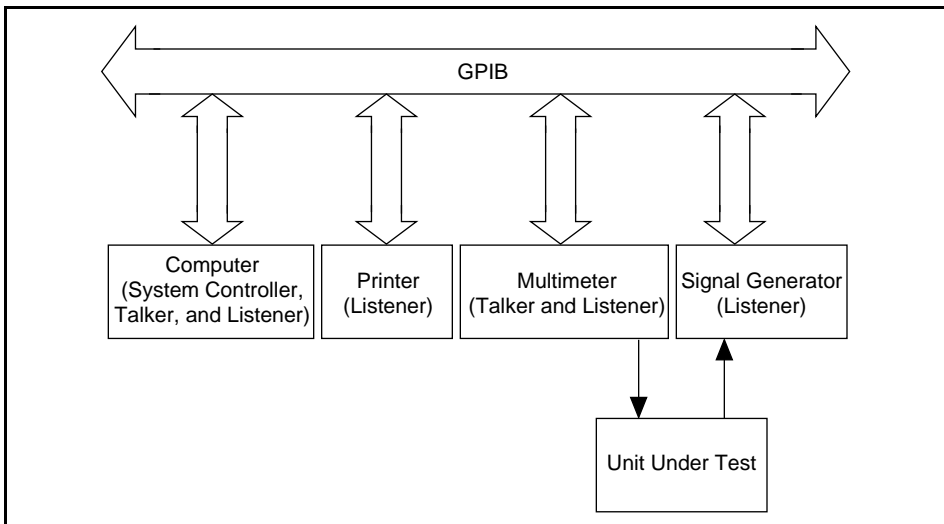

Figure 1-2. Typical Extension System (Logical Configuration)

The GPIB-140 and GPIB-140/2 bus extenders comply with the specifications of the ANSI/IEEE Standard 488.1-1987 and the ANSI/IEEE Standard 488.2-1992, including the Find Listeners protocol. With the GPIB extenders, you can overcome the following two configuration restrictions imposed by ANSI/IEEE Standard 488.1-1987:

- A cable length limit of 20 m total per contiguous bus or 2 m times the number of devices on the bus, whichever is smaller.
- An electrical loading limit of 15 devices per contiguous bus.

Each GPIB-140 system extends the GPIB to a maximum distance of 1 km, and each GPIB-140/2 system extends the GPIB to a maximum distance of 2 km. Both types of systems extend the loading limit to 28 devices (including the GPIB extenders), without sacrificing speed or performance. These point-to-point extension systems can be connected in series for longer distances or in star patterns for additional loading.

The maximum data transfer rate over the extension is 2.2 Mbytes/s using HS488 protocol. The GPIB extender uses a buffered transfer technique with a serial extension bus to get maximum performance while keeping the cabling cost at a minimum. Furthermore, there is no speed degradation for transfers between devices on the same side of the extension. The GPIB extender also has error-checking capabilities to ensure successful data transmission over the fiber optic link.

Because the GPIB-140 and the GPIB-140/2 are functionally transparent extenders, the same GPIB communications and control programs that work with an unextended system can work with an extended system. The *Parallel Poll Response (PPR) Modes* section of Chapter 3, *Configuration and Operation*, discusses one minor exception to this transparency in conducting parallel polls.

Chapter 2

Connection

This chapter describes how to connect the GPIB extender and verify that it is operating properly.

Configure the DIP Switch

The 3-bit DIP switch selects the operation mode of the GPIB extender. Each GPIB extender is shipped from the factory with the DIP switch set for unbuffered transfer mode, latched parallel poll (PPR) response, and HS488 disabled mode. Figure 2-1 shows the factory default setting of the DIP switch. Refer to Chapter 3, *Configuration and Operation*, for information on setting the operating mode for your application.

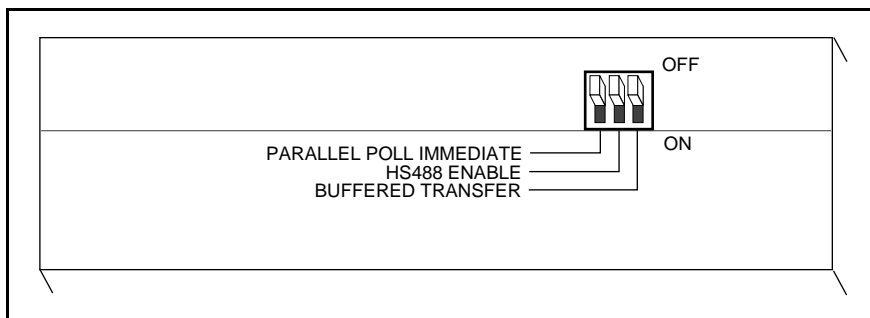

Figure 2-1. DIP Switch Default Setting

Connect the Hardware

Step 1. Connect the Cables

Follow these steps to connect the cables to both GPIB extenders:

1. Make sure that the power switch on each GPIB extender is in the OFF position.
2. Connect the fiber optic cable to both GPIB extenders. The fiber optic cable has two connectors on each end. Connect the connector marked T (transmit) to the connector marked TRANS on the side panel of the GPIB extender. Connect the connector marked R (receive) to the connector marked RCVR on the side panel of the GPIB extender.

- a. Remove the caps on the connectors.
- b. Align the notch on each cable connector to the slot on the side panel connector.
- c. Firmly push in the cable connector and rotate clockwise until the sleeve locks on to the side notch of the side panel connector.

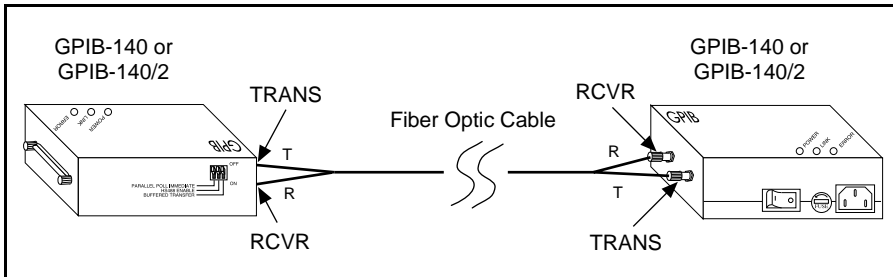

Figure 2-2. GPIB Extenders with Fiber Optic Cable Connected

3. Connect a GPIB cable to each GPIB extender and tighten the thumb screws on the connector. Connect the other end to your GPIB system. Be sure to follow all IEEE 488.1 cabling restrictions. Refer to the *Configuration Requirements* section of Appendix A, *Operation of the GPIB*, for typical restrictions.
4. Plug the utility power cord of each GPIB extender into an AC outlet of the correct voltage. Then plug the other end of the power cord into the GPIB-140.

Step 2. Switch On Your GPIB Extender

Power on each GPIB extender. The **POWER** LED should come on immediately. The **LINK** LED comes on only when both extenders are on and the fiber optic cable has been properly connected between them.

If the **POWER** LED does not come on immediately, check to make sure that power is supplied to the extender.

Optional Self-Test

Each GPIB extender is equipped with a self-test that determines if the GPIB extender receivers, transmitters, and packet transmission and reception circuitry are operating correctly.

Complete the following steps to run the self-test with the fiber optic cable.

1. Turn the GPIB extender power switch to the OFF position.
2. Disconnect the fiber optic cable from the GPIB extender.
3. Turn the GPIB extender power switch to the ON position.

At this point, the **POWER** LED lights up, indicating that power is supplied to the extender. The **LINK** LED remains off.

4. Connect the connector marked T (transmit) on one end of the fiber optic cable to the connector marked TRANS on the side panel of the GPIB extender.
5. Connect the connector marked R (receive) on the opposite end of the fiber optic cable to the connector marked RCVR on the side panel of the GPIB extender.

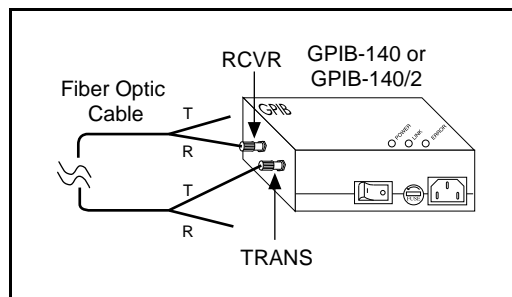

Figure 2-3. GPIB Extender Configured for Optional Self-Test

At this point, the **LINK** LED should light up, indicating that the cable has been connected. The **ERROR** LED should remain off to show that the GPIB extender is operating properly.

Chapter 3

Configuration and Operation

This chapter describes how to configure and operate a GPIB-140 or GPIB-140/2 system.

Data Transfer Modes

The GPIB extender has two data transfer modes: unbuffered mode and buffered mode. The data transfer mode determines how data is transmitted across the extension.

Unbuffered Mode

In unbuffered mode, each data byte is transmitted using the GPIB double-interlocked handshaking protocol. For long data streams, transfers using unbuffered mode are slower than transfers using buffered mode. However, the GPIB extension is transparent in unbuffered mode.

Buffered Mode

In buffered mode, the GPIB extenders use FIFO (first-in-first-out) buffers to buffer data between the remote and local units. For long data streams, you can obtain a much higher data throughput with buffered mode than with unbuffered mode.

Consider the following situation: a GPIB device on the local side of the extension is addressed to talk, another device on the remote side is addressed to listen. When the talking device sources data bytes, the GPIB extenders accept the data bytes and store them in a FIFO buffer. At the same time, the GPIB extenders read data from the FIFO buffer and source data bytes to the Listener. Whenever the FIFO buffer contains data, the number of bytes sourced by the Talker differs from the number of bytes accepted by the Listener. Because of this behavior, a few applications may not operate properly in buffered mode.

GPIB command bytes are not stored in the FIFO buffers; they are transmitted using the GPIB double-interlocked handshaking protocol.

Setting the Data Transfer Mode

The two GPIB extenders in the extension system do not need to be set to the same data transfer mode. Use switch position 1 on the DIP switch of each GPIB extender to set the data transfer mode. Slide the switch down to the ON position to set buffered mode; slide the switch up to set unbuffered mode. See Figure 3-1.

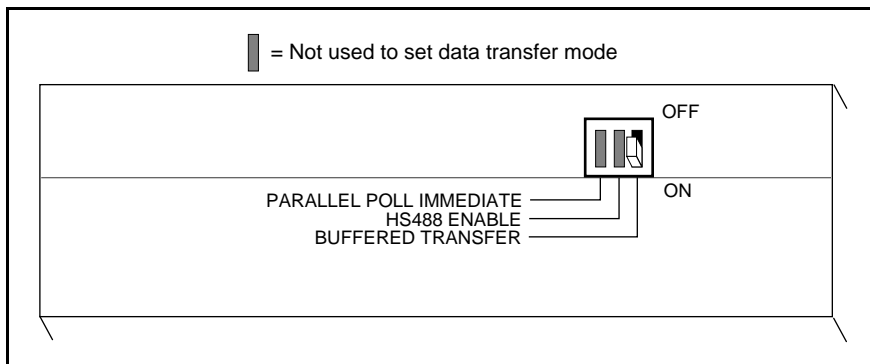

Figure 3-1. Switch Setting for Buffered Data Transfer Mode

HS488 Mode

The GPIB extender has the capability to handle data transfers using the HS488 protocol. HS488 specifies a means of transferring data among two or more devices using a noninterlocked handshake protocol. By using HS488, you can transfer data at rates higher than rates possible using the IEEE 488.1 protocol. For more information on HS488, refer to Appendix C, *Introduction to HS488*.

HS488 Disabled

With HS488 disabled, the GPIB extender sources and accepts data using a three-wire handshake protocol, even if both the Talker and Listener are able to transfer data using the HS488 protocol.

HS488 Enabled

When HS488 is enabled, the GPIB extender accepts data using the HS488 protocol after the Talker indicates that it wants to issue high-speed transfers. When functioning as a Talker, the GPIB extender always attempts to use the high-speed mode when HS488 is enabled. FIFO buffers are always used to buffer data during HS488 transfers, even if the switch that controls the data transfer mode is set to unbuffered mode. While using HS488 protocol with the GPIB extender, the GPIB cable length should be set to 5 m in the configuration utility of your IEEE 488.2 driver software for both the local and the remote system.

Setting the HS488 Mode

The two GPIB extenders in the extension system do not need to be set to the same HS488 mode. However, the maximum data transfer rate is achieved when both sides in the extension system are doing transfers using HS488.

Use switch position 2 on the DIP switch of each GPIB extender to set the HS488 mode. Slide the switch down to the ON position to enable the HS488 mode; slide the switch up to disable the HS488 mode. See Figure 3-2.

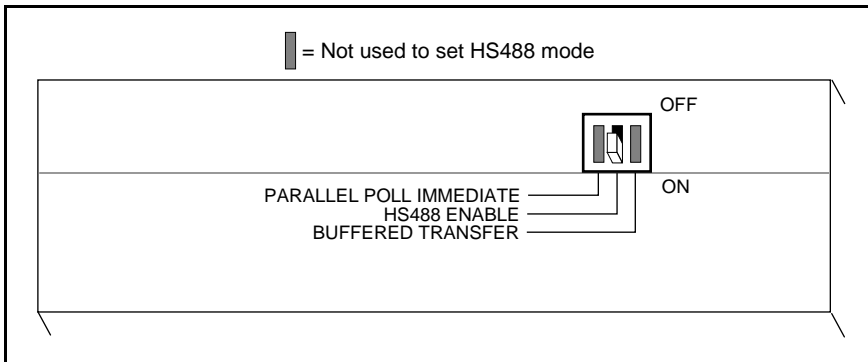

Figure 3-2. Switch Setting for HS488 Mode (Enabled)

Parallel Poll Response (PPR) Modes

According to ANSI/IEEE Standard 488.1-1987, devices must respond to a parallel poll within 200 ns after the Identify (IDY) message—Attention (ATN) and End or Identify (EOI)—is asserted by the Controller-In-Charge (CIC). The Controller waits at least 2 μ s before reading the Parallel Poll Response (PPR). In many cases, a remote device on an extended system cannot respond to parallel polls this quickly because of cable propagation delays. You can solve this problem using one of the following two approaches in your application program:

- Specify in your program that the Controller must allow enough time to receive the response. If you are able to do this, it is the easiest solution. For more information about this option, see the *Immediate PPR Mode* section, later in this chapter. If you are using National Instruments IEEE 488.2 driver software, you can use your software configuration utility to set the amount of time the Controller waits.
- Conduct two consecutive parallel polls and use the second response. For more information about this option, see the *Latched PPR Mode* section, later in this chapter.

Immediate PPR Mode

In immediate PPR mode, the GPIB extenders do not use the internal PPR data register. When a Controller on the local GPIB system asserts IDY, the local GPIB extender sends the IDY message to the remote bus and the response is returned as fast as propagation delays permit. In your application program or driver configuration utility, the Controller must allow time to receive the response.

Latched PPR Mode

In latched PPR mode, the GPIB extenders use an internal PPR data register. When a Controller on the local GPIB system asserts IDY, the local GPIB extender responds by outputting the contents of the PPR data register to the local GPIB data lines. At the same time, a parallel poll message is sent to the remote bus. When the local IDY signal is unasserted, the PPR from the remote system is loaded into the internal PPR data register. Consequently, the register always contains the response of the previous complete poll. To obtain the response of both local and remote GPIB systems, your application should execute two consecutive parallel polls and use the second response.

The software driver library of most Controllers contains an easy-to-use parallel poll function. If, for example, the function is called `ibrpp` and your application is written in BASIC, the sequence to conduct a poll in latched PPR mode might be similar to the following sequence:

```
CALL ibrpp (brd0%, ppr%)  
CALL ibrpp (brd0%, ppr%)  
IF ppr > 0 GOTO 300
```

Choosing the PPR Mode

Choosing the right PPR mode depends on the type of Controller present in the GPIB system and the length of cable between the GPIB-140 extenders. However, if your application does not use parallel polls, the PPR mode does not matter.

Some Hewlett-Packard GPIB Controllers remain in a parallel poll state with IDY asserted whenever they are not performing another function. A change in the response causes an interrupt of the application program. In some Controllers, the IDY signal is toggled on and off, and the duration of the signal can be varied to accommodate delayed responses over extenders. When used with any of these types of Controllers, the GPIB extender should be set to immediate PPR mode.

Most other Controllers pulse the IDY signal for about 2 μ s and expect a response within that time. When used with this type of Controller, the GPIB extender should use latched PPR mode if the cable between the extenders is longer than 60 m. For shorter cable distances, you should use immediate PPR mode.

The two GPIB extenders in the extension system do not need to be set to the same PPR mode. The PPR mode of the local GPIB extender should be chosen to accommodate the Controllers on the local GPIB system. Likewise, the PPR mode of the remote GPIB extender should be chosen to accommodate the Controllers on the remote GPIB system. If no Controllers are physically connected to one of the GPIB extenders, the PPR mode of that GPIB extender has no effect on the system.

Setting the PPR Mode

Use switch position 3 on the DIP switch of each GPIB extender to set the PPR mode. Slide the switch down to the ON position to set immediate PPR mode; slide the switch up to set latched PPR mode. See Figure 3-3.

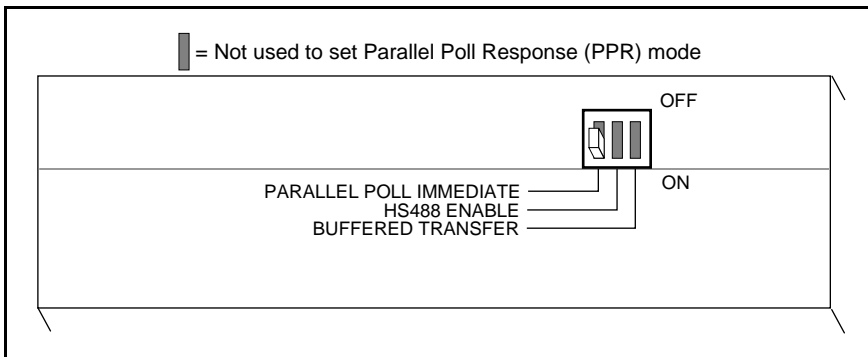

Figure 3-3. Switch Setting for Immediate Parallel Poll Response (PPR) Mode

Operating the Extension System

The GPIB-140 or GPIB-140/2 extension system is fully operational when power is supplied to both units and the fiber optic cable has been properly connected.

Three indicator LEDs labeled **POWER**, **LINK**, and **ERROR**, give information about the operational status of the GPIB extender.

POWER LED

The **POWER** LED is lit whenever power is supplied to the GPIB extender and the power switch is in the ON position.

LINK LED

The **LINK LED** is lit when both GPIB extenders are powered on and the transmission cable is properly connected to both extenders. During operation, the **LINK LED** turns off if the cable is disconnected from the receiver of the GPIB extender, or if either GPIB extender is powered off.

ERROR LED

The **ERROR LED** is lit if the GPIB extender receives corrupted data. The **ERROR LED** turns off after the GPIB extender starts re-transmission and has received the first re-transmitted data byte without error.

Chapter 4

Theory of Operation

This chapter describes how the GPIB extender circuitry operates.

The information in this chapter assumes that you have a basic knowledge of the GPIB. If you are a first-time user or you would like to review the basics, refer to Appendix A, *Operation of the GPIB*.

Figure 4-1 shows a model of a GPIB extender. The extender is made up of five layers. Each layer can be connected to the corresponding layer of another extender at the remote side to form a complete link.

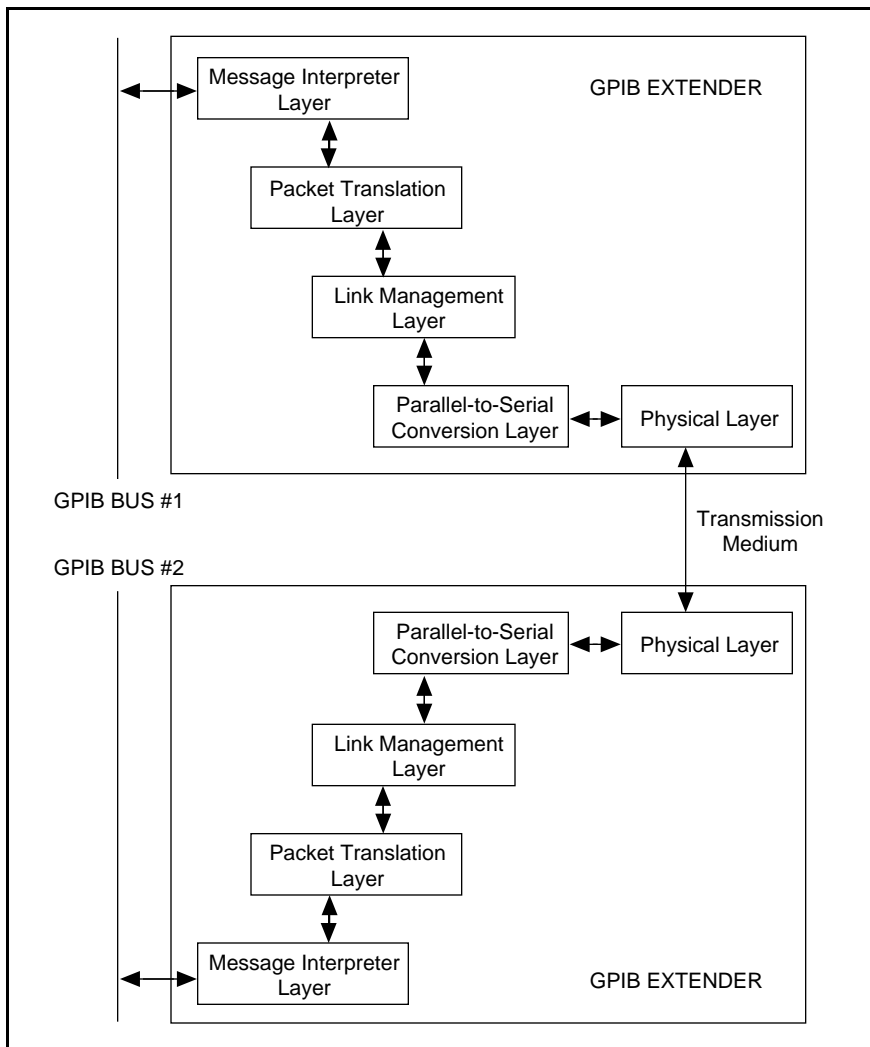

Figure 4-1. GPIB Extender Block Diagram

Message Interpreter Layer

The Message Interpreter Layer handles the handshake between the GPIB extender and other devices on the GPIB. At the same time, it monitors the activities occurring on the GPIB and translates them into equivalent GPIB local and remote messages. These messages are sent to the Packet Translation Layer.

Packet Translation Layer

The Packet Translation Layer converts the messages it receives to packets and sends them to the Link Management Layer. It can also receive packets from the Link Management Layer and convert them back to local or remote GPIB messages.

Link Management Layer

The Link Management Layer receives packets from the Packet Translation Layer. It sends the packets to the Parallel-to-Serial Conversion Layer, and at the same time, it stores them in a local buffer. If a transmission error occurs, the Link Management Layer can re-send the packets from this local buffer. The Link Management Layer also receives packets from the Parallel-to-Serial Layer and checks the packets for transmission errors. If no error is detected, the packets are sent to the Packet Translation Layer. If a transmission error is detected, the Link Management Layer will initiate re-transmission.

Parallel-to-Serial Translation Layer

The Parallel-to-Serial Conversion Layer accepts packets from the Link Management Layer, converts them into serial data, and sends the data out to the Physical Layer. It also extracts serial bits from the Physical Layer, reconstructs them back into packets, and presents them to the Link Management Layer.

Physical Layer

The Physical Layer handles the transmitting and receiving of serial data over the fiber optic link.

Appendix A

Operation of the GPIB

This appendix describes some basic concepts you should understand to operate the GPIB. It also contains a description of the physical and electrical characteristics and the configuration requirements of the GPIB.

Types of Messages

Communication among interconnected GPIB devices is achieved by passing messages through the interface system. The GPIB carries device-dependent messages and interface messages.

- Device-dependent messages, often called *data* or *data messages*, contain device-specific information such as programming instructions, measurement results, machine status, and data files.
- Interface messages manage the bus itself. They are usually called *commands* or *command messages*. Interface messages perform such tasks as initializing the bus, addressing and unaddressing devices, and setting device modes for remote or local programming.

The term *command* as used here should not be confused with some device instructions which can also be called commands. Such device-specific instructions are actually data messages.

Talkers, Listeners, and Controllers

A Talker sends data messages to one or more Listeners. The Controller manages the flow of information on the GPIB by sending commands to all devices.

Devices can be Listeners, Talkers, and/or Controllers. A digital voltmeter, for example, is a Talker and may be a Listener as well.

The GPIB is a bus like an ordinary computer bus, except that the computer has its circuit cards interconnected via a backplane bus, whereas the GPIB has stand-alone devices interconnected via a cable bus.

The role of the GPIB Controller can also be compared to the role of the CPU of a computer, but a better analogy is to the switching center of a city telephone system. The switching center (Controller) monitors the communications network (GPIB). When the center (Controller) notices that a party (device) wants to make a call (send a data message), it connects the caller (Talker) to the receiver (Listener).

The Controller addresses a Talker and a Listener before the Talker can send its message to the Listener. After the message is transmitted, the Controller may unaddress both devices.

Some bus configurations do not require a Controller. For example, one device may always be a Talker (called a Talk-only device) and there may be one or more Listen-only devices.

A Controller is necessary when the active or addressed Talker or Listener must be changed. The Controller function is usually handled by a computer.

With the GPIB interface board and its software your personal computer plays all three roles.

- Controller – to manage the GPIB
- Talker – to send data
- Listener – to receive data

The Controller-In-Charge and System Controller

Although there can be multiple Controllers on the GPIB, only one Controller at a time is active or Controller-In-Charge (CIC). Active control can be passed from the current CIC to an idle Controller. Only one device on the bus, the System Controller, can make itself the CIC. The GPIB interface board is usually the System Controller.

GPIB Signals and Lines

The interface system consists of 16 signal lines and 8 ground return or shield drain lines.

The 16 signal lines are divided into the following three groups.

- Eight data lines
- Three handshake lines
- Five interface management lines

Data Lines

The eight data lines, DIO1 through DIO8, carry both data and command messages. All commands and most data use the 7-bit ASCII or ISO code set, in which case the eighth bit, DIO8, is unused or used for parity.

Handshake Lines

Three hardware handshake lines asynchronously control the transfer of message bytes between devices. This process is a three-wire interlocked handshake, and it guarantees that devices send and receive message bytes on the data lines without transmission error. Table A-1 summarizes the GPIB handshake lines.

Table A-1. GPIB Handshake Lines

Line	Description
NRFD (not ready for data)	Listening device is ready/not ready to receive a message byte. Also used by the Talker to signal high-speed transfers (HS488).
NDAC (not data accepted)	Listening device has/has not accepted a message byte.
DAV (data valid)	Talking device indicates signals on data lines are stable (valid) data.

Interface Management Lines

Five GPIB hardware lines manage the flow of information across the bus. Table A-2 summarizes the GPIB interface management lines.

Table A-2. GPIB Interface Management Lines

Line	Description
ATN (attention)	Controller asserts ATN when it sends commands and unasserts ATN when it sends data messages.
IFC (interface clear)	System Controller drives the IFC line to initialize the bus and make itself CIC.
REN (remote enable)	System Controller drives the REN line to place devices in remote or local program mode.
SRQ (service request)	Any device can drive the SRQ line to request service from the Controller asynchronously.
EOI (end or identify)	Talker uses the EOI line to mark the end of a data message. Controller uses the EOI line when it conducts a parallel poll.

Physical and Electrical Characteristics

Devices are usually connected with a cable assembly consisting of a shielded 24 conductor cable with both a plug and receptacle connector at each end. This design allows devices to be linked in either a linear or a star configuration, or a combination of the two. See Figures A-1 and A-2.

The standard connector is the Amphenol or Cinch Series 57 *Microribbon* or *Amp Champ* type. An adapter cable using a non-standard cable and/or connector is used for special interconnection applications.

The GPIB uses negative logic with standard TTL (transistor-transistor logic) level. When DAV is true, for example, it is a TTL low level ($\leq 0.8V$), and when DAV is false, it is a TTL high level ($\geq 2.0V$).

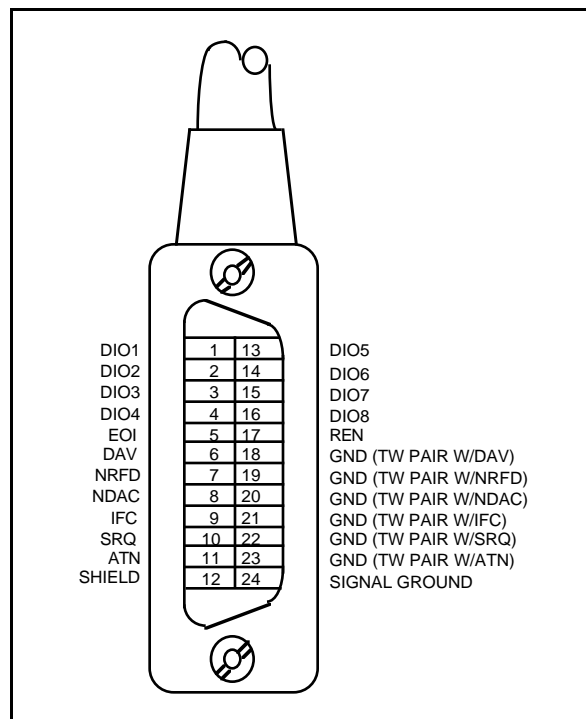

Figure A-1. GPIB Connector and the Signal Assignment

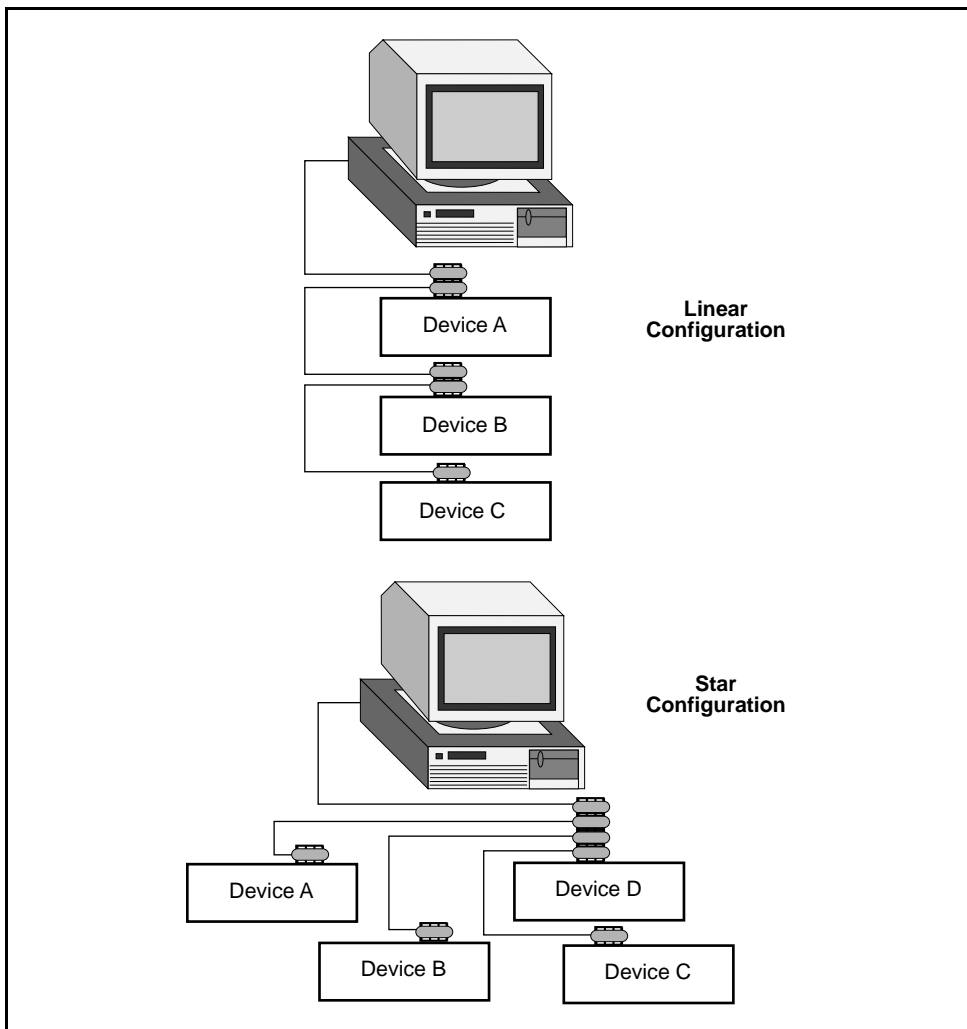

Figure A-2. Linear and Star System Configuration

Configuration Requirements

To achieve the high data transfer rate that the GPIB was designed for, the physical distance between devices and the number of devices on the bus are limited.

The following restrictions are typical.

- A maximum separation of 4 m between any two devices and an average separation of 2 m over the entire bus.

- A maximum total cable length of 20 m.
- No more than 15 devices connected to each bus, with at least two-thirds powered on.

Appendix B

Specifications

This appendix lists the specifications of the GPIB extender.

Table B-1. System Configuration

Configuration	Specification
Distance per GPIB-140 extension	Up to 1 km
Distance per GPIB-140/2 extension	Up to 2 km
Loading per extension	Up to 13 additional devices (28 total devices in the extension system, including the extenders)
Multiple extensions	Permitted in any combination of star or linear pattern

Table B-2. Performance Characteristics

Characteristic	Specification
Maximum transfer rate Buffered mode, non-HS488 HS488 handshake Unbuffered mode	1.05 Mbytes/s 2.2 Mbytes/s 200 kbytes/s
Functionality	Transparent GPIB operation except for latched parallel polls
Interlocked IEEE 488 handshake	Maintained across the extension in unbuffered mode
IEEE 488 capability identification codes	SH1 Complete Source Handshake AH1 Complete Acceptor Handshake T5, TE5 Complete Talker L3, LE3 Complete Listener SR1 Complete Service Request RL1 Complete Remote Local PP1,2 Complete Parallel Poll DC1 Complete Device Clear DT1 Complete Device Trigger C1-5 Complete Controller E2 Tri-state GPIB driver
HS488 capability identification codes	SHE HS488 Source Handshake AHE HS488 Acceptor Handshake

Table B-3. Operation Characteristics

Characteristic	Specification
Architecture	Point-to-point (not multi-drop) transmission
Operating modes	Buffered or unbuffered (interlocked) mode
HS488 modes	HS488 enabled or HS488 disabled mode
Parallel Poll Response modes	Immediate Parallel Poll Response mode or Latched Parallel Poll Response mode

Table B-4. Electrical Characteristics

Characteristic	Specification
Transmission interface circuit for the GPIB-140	Optical transmitter and receiver (HFBR1414, HFBR2416, or equivalent) with ST-style optical cable connectors
Transmission interface circuit for the GPIB-140/2	Optical transmitter and receiver (HFBR1312, HFBR1316, or equivalent) with ST-style optical cable connectors
GPIB interface load	Two standard loads, AC and DC
Power supply unit	100-120 VAC, 50-60 Hz or 220-240 VAC, 50-60 Hz
Maximum current requirement	100-120 VAC, 120 mA or 220-240 VAC, 80 mA
Fuse rating and type	100-120 VAC, 300 mA, UL/CSA approved or 220-240 VAC, 500 mA, IEC approved

Table B-5. Environmental Characteristics

Characteristic	Specification
Operating temperature	0° to 40° C
Storage temperature	-20° to 70° C
Humidity	10% to 90% noncondensing conditions
EMI	FCC Class A Verified

Table B-6. Physical Characteristics

Characteristic	Specification
Case dimensions	8.89 cm by 14.35 cm by 4.11 cm (3.5 in. by 5.65 in. by 1.62 in.)
Case material	All metal enclosure
Weight	.25 kg (.55 lb)
GPIB cable	Type X1 or X2 shielded GPIB cable
Transmission cable for the GPIB-140	3.0 x 6.5 mm cable diameter 62.5/125 micron core/clad with NA=0.275 850 nm operating wavelength 3.0 dB/km attenuation Duplex style, terminated with ST-style connectors
Transmission cable for the GPIB-140/2	3.0 x 6.5 mm cable diameter 62.5/125 micron core/clad with NA=0.275 1300 nm operating wavelength 1 dB/km attenuation Duplex style, terminated with ST-style connectors

Appendix C

Introduction to HS488

This appendix describes HS488 and the sequence of events in high-speed data transfers.

HS488 is a proposed addition to the ANSI/IEEE Standard 488.1-1987. HS488 specifies using a noninterlocked handshake protocol to transfer data between two or more devices. By using the HS488 protocol, devices can transfer data at rates that are higher than the rates that are possible by using the IEEE 488.1 protocol.

Objectives of HS488

Fast Transfer Rates

HS488 enables transfer rates that are substantially faster than the IEEE 488.1 standard transfer rates. In small systems, the raw transfer rate can be up to 8 Mbytes/s. The faster raw transfer rates improve system throughput in systems where devices send long blocks of data. The physical limitations of the cabling system, however, limit the transfer rate.

Compatibility with Existing IEEE 488.1 Devices

HS488 devices are compatible with 488.1 devices. IEEE 488.1 devices and HS488 devices can exist in the same system, and they communicate with each other using 488.1 protocols.

A Controller does not need to be capable of HS488 noninterlocked transfers when connected to an HS488 device. While ATN is asserted, a Controller sources multiline messages to HS488 devices just as it sources multiline messages to any 488.1 devices.

No Additional Software Overhead—Automatic HS488 Detection

Addressed HS488 devices detect whether other addressed devices are also HS488 capable without the interaction of the Controller.

No Changes to the IEEE 488.2 Standard

The HS488 protocol requires no changes to the IEEE 488.2 standard. HS488 devices do not need to be 488.2 compliant.

No Added Cabling Restrictions beyond IEEE 488.1

Systems that meet the IEEE 488.1 requirements for *higher speed operation* meet the HS488 requirements.

You should be aware of the limitations that affect HS488 usage:

- Cabling requirements: Same as IEEE 488.1.
- Does not reduce software overhead.
- System throughput increases depend on data block size.

IEEE 488.1 Requirements for Higher Speed Operation (T1 Delay ≥ 350 ns)

The IEEE 488.1 standard specifies that devices intending high-speed operation must use three-state, 48-mA drivers on most signals. Each device must add no more than 50-pF capacitance on each signal, and all devices must be powered on.

The total cable length in a system must be no more than 15 m, or 1 m times the number of devices in the system.

Additional HS488 System Requirements

An HS488 system must meet the IEEE 488.1 standard requirements described in the preceding section, and HS488 devices must implement three new interface functions. Talking devices must use the Source Handshake Extended (SHE) interface function, which is an extension of the IEEE 488.1 SH function. Listening devices use the Acceptor Handshake Extended (AHE) interface function, which is an extension of the IEEE 488.1 AHE function. Accepting devices must have at least a small buffer to store received data. HS488 devices must implement the Configuration (CF) interface function. At system power on, the Controller uses previously undefined multiline messages to configure HS488 devices. The CF function enables devices to interpret these multiline messages.

Sequence of Events in Data Transfers

Figure C-1 shows a typical IEEE 488.1 data transfer and an HS488 data transfer. The HS488 protocol modifies the 488.1 Source Handshake and Acceptor Handshake functions. At the beginning of each data transfer, the HS488 source and acceptor functions determine whether all active Talkers and Listeners are capable of HS488 transfers. If the addressed devices are HS488 capable, they use the HS488

noninterlocked handshake protocol for that data transfer. If any addressed device is not HS488 compliant, the transfer continues using the standard three-wire handshake.

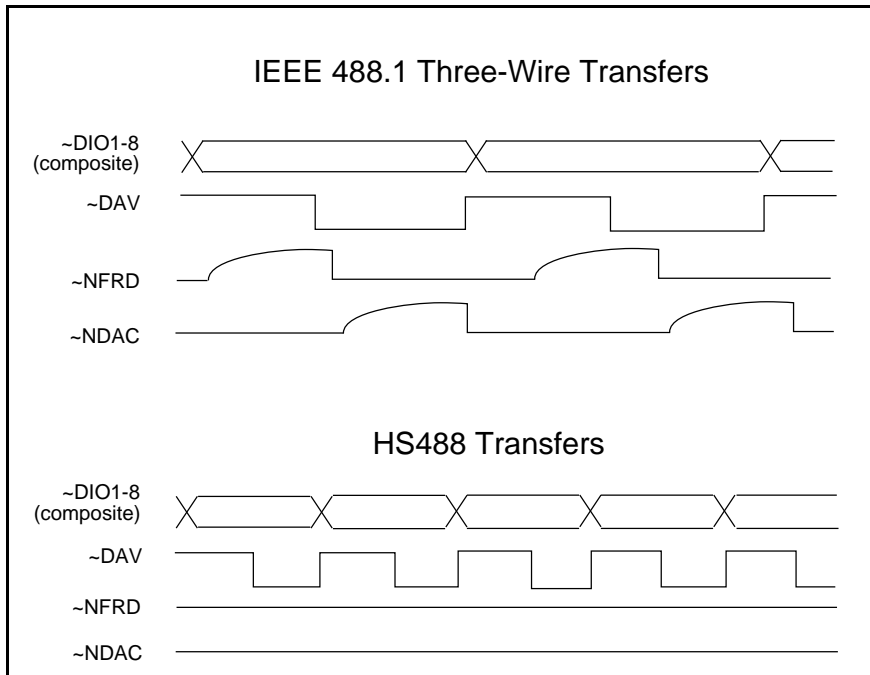

Figure C-1. IEEE 488.1 and HS488 Transfers

The following sections describe the sequence of events for data transfers that involve HS488 devices. There are three HS488 transfer cases:

- Talker is HS488—Listener is HS488.
- Talker is HS488—Listener is not HS488.
- Talker is not HS488—Listener is HS488.

Case 1: Talker and Listener Are HS488 Capable

The following steps describe a typical sequence of events in an HS488 data transfer in which the Talker and Listener are both HS488 capable. Refer to Figure C-2.

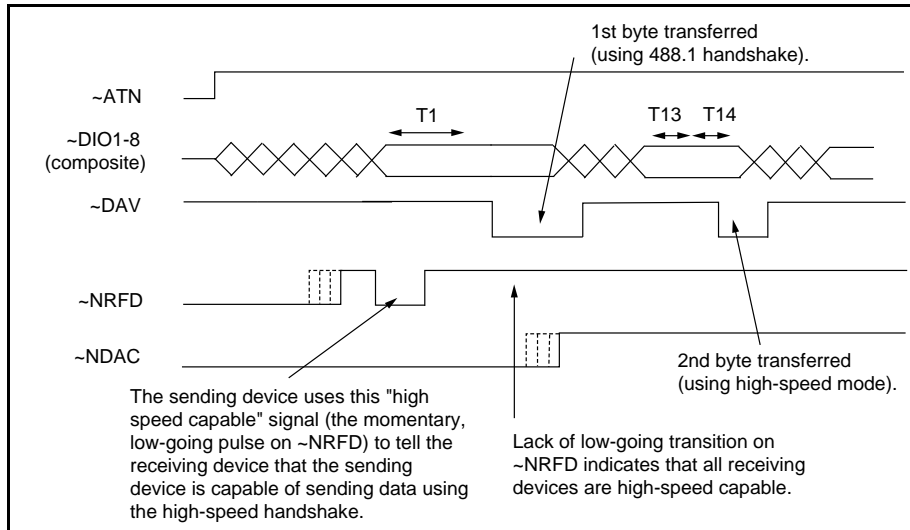

Figure C-2. Talker and Listener Are HS488 Capable

1. The Controller addresses devices and becomes Standby Controller by unasserting ATN.
2. The Listener asserts NDAC and NRFD.
3. The Listener unasserts NRFD as it becomes ready to accept a byte.
4. After allowing time for the Listener to detect NRFD unasserted, the Talker indicates that it is capable of HS488 operation by sending the HSC message. To send the HSC message true, the Talker asserts the NRFD signal.
5. After allowing time for the Listener to respond to the HSC message, the Talker sends the HSC message false. To send the HSC message false, the Talker unasserts the NRFD signal.
6. When the Talker has a byte ready to send, it drives the data on the DIO signal lines, allows some settling time, and asserts DAV.

7. The Listener unasserts NDAC. HS488 Listeners do not assert NRFD as 488.1 devices would. Because of this behavior, the Talker determines that the addressed Listener is capable of HS488 transfers.
8. The Talker unasserts DAV and begins to drive the next data byte on the GPIB.
9. After allowing some settling time, the Talker asserts DAV.
10. The Listener latches the byte in response to the assertion (falling) edge of DAV.
11. After allowing some hold time, the Talker unasserts DAV and drives the next data byte on the DIO signal lines.
12. Steps 9–11 are repeated for each data byte.

Case 2: Talker Is HS488 Capable, But Listener Is Not HS488 Capable

The following steps describe a typical sequence of events in an HS488 data transfer in which the Talker is HS488 capable, but the Listener is not. Refer to Figure C-3.

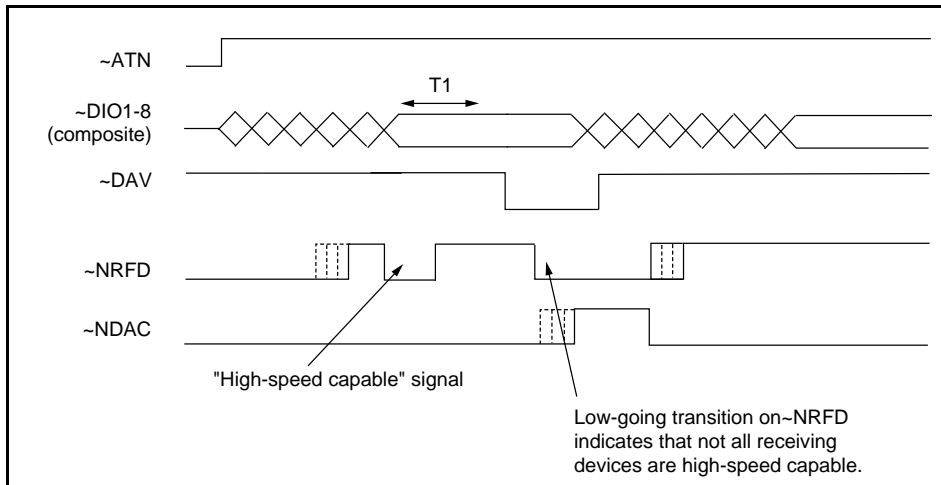

Figure C-3. Talker Is HS488 Capable, But Listener Is Not HS488 Capable

Steps 1–6 are identical to steps 1–6 in case 1, *Talker and Listener Are HS488 Capable*. The Listener ignores the HSC message from the Talker.

Step 7: The IEEE 488.1 Listener enters ACDS and asserts NRFD. Because of this behavior, the Talker determines that the addressed Listener is not capable of HS488 transfers. The Talker sources bytes using the IEEE 488.1 protocol.

Case 3: Talker Is Not HS488 Capable, But Listener Is HS488 Capable

The Talker does *not* send an HSC message to the Listener, but begins sourcing bytes by using the IEEE 488.1 protocol.

The Addressed Listener (HS488 or 488.1) accepts bytes by using the IEEE 488.1 standard three-wire handshake. Refer to Figure C-4.

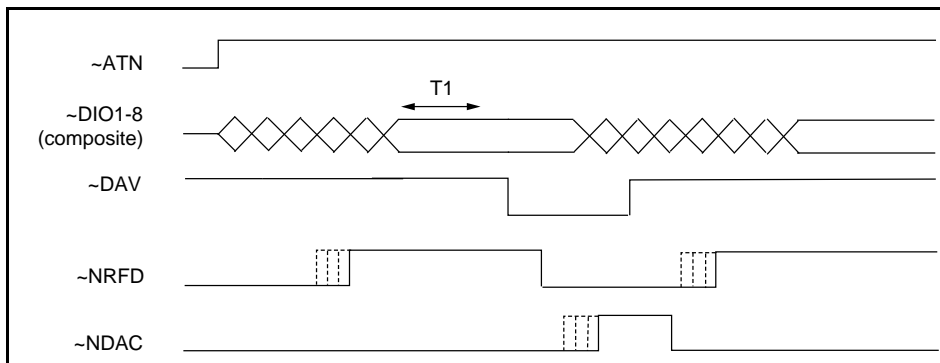

Figure C-4. Talker Is Not HS488 Capable, But Listener Is HS488 Capable

System Configuration

The HS488 Acceptor Handshake and Source Handshake interface functions depend on several time delays. Some of these delays are a function of the total system cable length.

The Controller must communicate this system configuration data to HS488 devices after the system powers on. The Controller configures HS488 devices by sourcing two multiline messages while ATN is true.

The first message is the Configuration Enable (CFE) message. The Controller sends the CFE message by driving a bit pattern (1E hex) that the IEEE 488.1 standard does not define on the DIO signal lines. The CFE message enables HS488 devices to interpret the SCG message that follows. The second message is a Secondary Command Group (SCG) message that contains the configuration data. The Secondary Command has the bit pattern $6n$ hex, where n is the meters of cable in the system. The Secondary Command Group includes CFG1-CFG15 in Appendix D, *Multiline Interface Messages*.

Appendix D

Multiline Interface Messages

This appendix lists the multiline interface messages and describes the mnemonics and messages that correspond to the interface functions.

The multiline interface messages are IEEE 488 defined commands that are sent and received with ATN asserted. The interface functions include initializing the bus, addressing and unaddressing devices, and setting device modes for local or remote programming. For more information on these messages, refer to the ANSI/IEEE Standard 488.1-1987, *IEEE Standard Digital Interface for Programmable Instrumentation*.

Multiline Interface Messages

<u>Hex</u>	<u>Oct</u>	<u>Dec</u>	<u>ASCII</u>	<u>Msg</u>	<u>Hex</u>	<u>Oct</u>	<u>Dec</u>	<u>ASCII</u>	<u>Msg</u>
00	000	0	NUL		20	040	32	SP	MLA0
01	001	1	SOH	GTL	21	041	33	!	MLA1
02	002	2	STX		22	042	34	"	MLA2
03	003	3	ETX		23	043	35	#	MLA3
04	004	4	EOT	SDC	24	044	36	\$	MLA4
05	005	5	ENQ	PPC	25	045	37	%	MLA5
06	006	6	ACK		26	046	38	&	MLA6
07	007	7	BEL		27	047	39	'	MLA7
08	010	8	BS	GET	28	050	40	(MLA8
09	011	9	HT	TCT	29	051	41)	MLA9
0A	012	10	LF		2A	052	42	*	MLA10
0B	013	11	VT		2B	053	43	+	MLA11
0C	014	12	FF		2C	054	44	,	MLA12
0D	015	13	CR		2D	055	45	-	MLA13
0E	016	14	SO		2E	056	46	.	MLA14
0F	017	15	SI		2F	057	47	/	MLA15
10	020	16	DLE		30	060	48	0	MLA16
11	021	17	DC1	LLO	31	061	49	1	MLA17
12	022	18	DC2		32	062	50	2	MLA18
13	023	19	DC3		33	063	51	3	MLA19
14	024	20	DC4	DCL	34	064	52	4	MLA20
15	025	21	NAK	PPU	35	065	53	5	MLA21
16	026	22	SYN		36	066	54	6	MLA22
17	027	23	ETB		37	067	55	7	MLA23
18	030	24	CAN	SPE	38	070	56	8	MLA24
19	031	25	EM	SPD	39	071	57	9	MLA25
1A	032	26	SUB		3A	072	58	:	MLA26
1B	033	27	ESC		3B	073	59	;	MLA27
1C	034	28	FS		3C	074	60	<	MLA28
1D	035	29	GS		3D	075	61	=	MLA29
1E	036	30	RS		3E	076	62	>	MLA30
1F	037	31	US	CFE	3F	077	63	?	UNL

Message Definitions

CFE [†]	Configuration Enable	MLA	My Listen Address
CFG [†]	Configure	MSA	My Secondary Address
DCL	Device Clear	MTA	My Talk Address
GET	Group Execute Trigger	PPC	Parallel Poll Configure
GTL	Go To Local	PPD	Parallel Poll Disable
LLO	Local Lockout		

[†]This multiline interface message is a proposed extension to the IEEE 488.1 specification to support the HS488 high-speed protocol.

Multiline Interface Messages

<u>Hex</u>	<u>Oct</u>	<u>Dec</u>	<u>ASCII</u>	<u>Msg</u>	<u>Hex</u>	<u>Oct</u>	<u>Dec</u>	<u>ASCII</u>	<u>Msg</u>
40	100	64	@	MTA0	60	140	96	`	MSA0,PPE
41	101	65	A	MTA1	61	141	97	a	MSA1,PPE,CFG1
42	102	66	B	MTA2	62	142	98	b	MSA2,PPE, CFG2
43	103	67	C	MTA3	63	143	99	c	MSA3,PPE,CFG3
44	104	68	D	MTA4	64	144	100	d	MSA4,PPE,CFG4
45	105	69	E	MTA5	65	145	101	e	MSA5,PPE,CFG5
46	106	70	F	MTA6	66	146	102	f	MSA6,PPE,CFG6
47	107	71	G	MTA7	67	147	103	g	MSA7,PPE,CFG7
48	110	72	H	MTA8	68	150	104	h	MSA8,PPE,CFG8
49	111	73	I	MTA9	69	151	105	i	MSA9,PPE,CFG9
4A	112	74	J	MTA10	6A	152	106	j	MSA10,PPE,CFG10
4B	113	75	K	MTA11	6B	153	107	k	MSA11,PPE,CFG11
4C	114	76	L	MTA12	6C	154	108	l	MSA12,PPE,CFG12
4D	115	77	M	MTA13	6D	155	109	m	MSA13,PPE,CFG13
4E	116	78	N	MTA14	6E	156	110	n	MSA14,PPE,CFG14
4F	117	79	O	MTA15	6F	157	111	o	MSA15,PPE,CFG15
50	120	80	P	MTA16	70	160	112	p	MSA16,PPD
51	121	81	Q	MTA17	71	161	113	q	MSA17,PPD
52	122	82	R	MTA18	72	162	114	r	MSA18,PPD
53	123	83	S	MTA19	73	163	115	s	MSA19,PPD
54	124	84	T	MTA20	74	164	116	t	MSA20,PPD
55	125	85	U	MTA21	75	165	117	u	MSA21,PPD
56	126	86	V	MTA22	76	166	118	v	MSA22,PPD
57	127	87	W	MTA23	77	167	119	w	MSA23,PPD
58	130	88	X	MTA24	78	170	120	x	MSA24,PPD
59	131	89	Y	MTA25	79	171	121	y	MSA25,PPD
5A	132	90	Z	MTA26	7A	172	122	z	MSA26,PPD
5B	133	91	[MTA27	7B	173	123	{	MSA27,PPD
5C	134	92	\	MTA28	7C	174	124		MSA28,PPD
5D	135	93]	MTA29	7D	175	125	}	MSA29,PPD
5E	136	94	^	MTA30	7E	176	126	~	MSA30,PPD
5F	137	95	_	UNT	7F	177	127	DEL	

PPE	Parallel Poll Enable	SPE	Serial Poll Enable
PPU	Parallel Poll Unconfigure	TCT	Take Control
SDC	Selected Device Clear	UNL	Unlisten
SPD	Serial Poll Disable	UNT	Untalk

Appendix E

Customer Communication

For your convenience, this appendix contains forms to help you gather the information necessary to help us solve technical problems you might have as well as a form you can use to comment on the product documentation. Filling out a copy of the *Technical Support Form* before contacting National Instruments helps us help you better and faster.

National Instruments provides comprehensive technical assistance around the world. In the U.S. and Canada, applications engineers are available Monday through Friday from 8:00 a.m. to 6:00 p.m. (central time). In other countries, contact the nearest branch office. You may fax questions to us at any time.

Corporate Headquarters

(512) 795-8248

Technical support fax: (800) 328-2203
(512) 794-5678

Branch Offices	Phone Number	Fax Number
Australia	03 9 879 9179	03 9 879 9422
Austria	0662 45 79 90 19	0662 45 79 90 0
Belgium	02 757 03 11	02 757 00 20
Denmark	45 76 71 11	45 76 26 00
Finland	90 502 2930	90 527 2321
France	1 48 14 24 14	1 48 14 24 24
Germany	089 714 60 35	089 741 31 30
Hong Kong	2686 8505	2645 3186
Italy	02 48301915	02 48301892
Japan	03 5472 2977	03 5472 2970
Korea	02 596 7455	02 596 7456
Mexico	5 202 2544	5 520 3282
Netherlands	03480 30673	03480 33466
Norway	32 84 86 00	32 84 84 00
Singapore	2265887	2265886
Spain	91 640 0533	91 640 0085
Sweden	08 730 43 70	08 730 49 70
Switzerland	056 20 51 55	056 20 51 51
Taiwan	02 737 4644	02 377 1200
U.K.	01635 523154	01635 523545

Technical Support Form

Photocopy this form and update it each time you make changes to your software or hardware, and use the completed copy of this form as a reference for your current configuration. Completing this form accurately before contacting National Instruments for technical support helps our applications engineers answer your questions more efficiently.

If you are using any National Instruments hardware or software products related to this problem, include the configuration forms from their user manuals. Use additional pages if necessary.

Name _____

Company _____

Address _____

Fax (____) _____ Phone (____) _____

Computer brand _____

Model _____ RAM _____ MB

Processor _____ Speed _____ MHz

Operating system _____

Display adapter _____

Mouse _____yes _____no

Other adapters installed _____

Hard disk capacity _____ MB Brand _____

Instruments used _____

National Instruments hardware product model _____

Revision _____

Configuration _____

National Instruments software product _____

Version _____

Configuration _____

(continues)

The problem is _____

List any error messages _____

The following steps will reproduce the problem _____

GPIB Extender Hardware and Software Configuration Form

Record the settings and revisions of your hardware and software on the line to the right of each item. Update this form each time you revise your software or hardware configuration, and use this form as a reference for your current configuration.

National Instruments Products

- GPIB Extender and Revision Number
– GPIB-140 Revision _____
or
–GPIB-140/2 Revision _____
- DIP Switch Settings _____
- National Instruments GPIB Interface _____
- National Instruments Software _____

Other Products

- Computer Make and Model _____
- Operating System Version _____
- Number of GPIB Devices on Bus _____
- Other GPIB Devices in System _____

Documentation Comment Form

National Instruments encourages you to comment on the documentation supplied with our products. This information helps us provide quality products to meet your needs.

Title: **GPIB-140 User Manual**

Edition Date: **June 1995**

Part Number: **320911B-01**

Please comment on the completeness, clarity, and organization of the manual.

(continues)

If you find errors in the manual, please record the page numbers and describe the errors.

Thank you for your help.

Name _____

Title _____

Company _____

Address _____

Phone (_____) _____

Mail to: Technical Publications
 National Instruments Corporation
 6504 Bridge Point Parkway, MS 53-02
 Austin, TX 78730-5039

Fax to: Technical Publications
 National Instruments Corporation
 MS 53-02
 (512) 794-5678

Glossary

Prefix	Meaning	Value
p-	pico-	10^{-12}
n-	nano-	10^{-9}
μ -	micro-	10^{-6}
m-	milli-	10^{-3}
c-	centi-	10^{-2}
k-	kilo-	10^3
M-	mega-	10^6

°	degrees
%	percent
A	amperes
AC	alternating current
ANSI	American National Standards Institute
ASCII	American Standards Code for Information Interchange
ASIC	application-specific integrated circuit
ATN	Attention
CIC	Controller-In-Charge
CPU	central processing unit
CSA	Canadian Standards Association
DAV	data valid
dB	decibels
DC	direct current
DIO	digital input/output
DIP	dual inline package
EOI	End or Identify
EOS	End of String
F	Farads
FCC	Federal Communications Commission
FIFO	first-in-first-out
g	grams
GPIB	General Purpose Interface Bus
hex	hexadecimal
Hz	hertz
IDY	Identify
IEC	International Electrotechnical Commission
IEEE	Institute of Electrical and Electronic Engineers
IFC	Interface Clear
lb	pounds
LED	light-emitting diode

Glossary

m	meters
MB	megabytes of memory
NA	Numerical Aperture
NDAC	Not Data Accepted
NRFD	Not Ready For Data
PPR	Parallel Poll Response
RAM	random-access memory
REN	Remote Enable
s	seconds
SRQ	Service Request
TTL	transistor-transistor logic
UL	Underwriters Laboratories
VAC	volts alternating current

Artisan Technology Group is an independent supplier of quality pre-owned equipment

Gold-standard solutions

Extend the life of your critical industrial, commercial, and military systems with our superior service and support.

We buy equipment

Planning to upgrade your current equipment? Have surplus equipment taking up shelf space? We'll give it a new home.

Learn more!

Visit us at artisanng.com for more info on price quotes, drivers, technical specifications, manuals, and documentation.

Artisan Scientific Corporation dba Artisan Technology Group is not an affiliate, representative, or authorized distributor for any manufacturer listed herein.

We're here to make your life easier. How can we help you today?

(217) 352-9330 | sales@artisanng.com | artisanng.com

