

SOLID STATE HIGH POWER WIDE BAND AMPLIFIER

MODEL NUMBER:

SS250M-700

OPERATING AND MAINTENANCE INSTRUCTIONS

DOCUMENT NUMBER MAN-70011,
SS250M-700 MNL. V1.0



WWW.THEEMCSHOP.COM



SALES@THEEMCSHOP.COM



844.423.7435



THE EMC SHOP, 7401 GALILEE RD. #160 ROSEVILLE, CA 95678

TABLE OF CONTENTS

<u>SECTION</u>	<u>DESCRIPTION</u>	<u>PAGE</u>
1.0	INTRODUCTION	3
2.0	GENERAL DESCRIPTION	5
3.0	Controller Operation	6
4.0	GENERAL INFORMATION	
4.1	Scope of This Manual	13
4.2	Operation Overview	13
4.3	N/A	
4.4	General Specifications	15
4.5	Protection Circuits	16
4.6	Status Indicators, Controls and Connectors	17
4.7	Status Indicators, Controls	19
5.0	PRINCIPALS OF OPERATION	
5.1	Proper Usage and Warnings	20
6.0	Remote INTERFACE	
6.1	Introduction.....	21
6.2	RS-232	21
6.3	ETHERNET	22
6.4	Remote Commands.....	23
7.0	MAINTENANCE AND SERVICING	
7.1	Periodic Maintenance	29
7.2	Servicing the Amplifier	29
7.3	Equipment Return Procedure.....	30
8.0	WARRANTY INFORMATION.....	31

LIST OF FIGURES

<u>FIGURE</u>	<u>DESCRIPTION</u>	<u>PAGE</u>
1.0	OUTLINE DRAWING	4
2.0-8.0	CONTROL OPERATION	6-12
9.0	SYSTEM BLOCK DIAGRAM	14
10.0	REAR PANEL ILLUSTRATION	17

LIST OF APPENDICES

<u>APPENDIX</u>	<u>DESCRIPTION</u>	<u>PAGE</u>
A	DATA SHEETS	32
B	DRAWINGS	33

SECTION 1.0

INTRODUCTION

Congratulations on the purchase of your new Wide Band Amplifier from © The EMC Shop, LLC. Your new Wide Band Amplifier incorporates the finest advancements in the state of the art electronics technology available in a compact, portable and versatile package. Your Wide Band Amplifier's quality, performance and trouble free operation depends on you thoroughly reading through this manual and familiarizing yourself with its proper operation and usage.

Your Wide Band Amplifier comes with the following accessories, be sure to check your packaging for the items listed below before disposing of the packaging.

CONTENTS

(For a typical Wide Band Amplifier)

<u>Quantity</u>	<u>Description</u>
1	SOLID STATE High Power Wide Band Amplifier, Model SS250M-700
1	Mating Connector or Power Line cable
1	Operation and Instruction Manual
1	Data Sheets (Included in Manual)

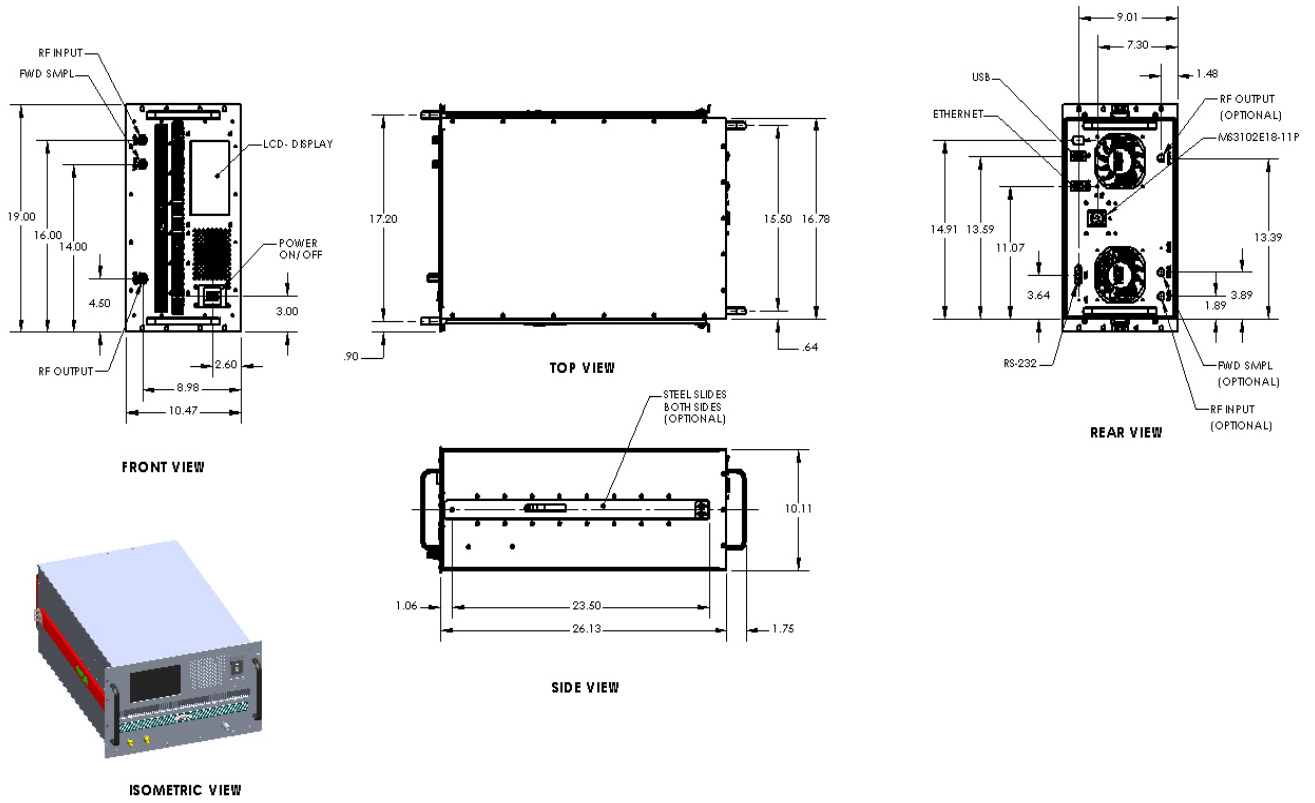

FIGURE 1.0
OUTLINE DRAWING

SECTION 2.0

GENERAL DESCRIPTION

© The EMC Shop, LLC (EMC) manufactured SOLID STATE Wide Band Amplifier is a Bench Top or rack mount amplifier providing a nominal 1000 Watts of RF power from 10MHz to 250 MHz, with output power of at least 1000 Watts. The minimum saturated output power at midband of the operating frequency range is more than 1000 Watts.

The Amplifier features a touch screen 7” high resolution [800x480] color TFT Display that displays continuous forward and reflected power metering. The display also provides the operator with operating status and self diagnostic fault indications.

The Amplifier incorporates protection circuits that monitors and controls so the amplifier cannot be damaged by any mismatched load.

The Amplifier has an Ethernet interface which allows the amplifier to be remotely controlled through the use of a computer.

To operate the Amplifier, connect a single phase power line cable (220 Vac line to Neutral) 3 wires to the Power Entry connector on the rear panel.

Section 3.0 SSA Controller Operation

3.1 Hardware Initialization

The local mode of operation will allow the user to exercise control over the parameters by way of button switches located toward the right of the screen. Pressing a button switch will toggle the switch position and will highlight its function.



Figure 2.0, Hardware Initialization Screen

Once the power is turned on the controller will boot and display the boot screen as shown above. It will only be displayed for a few seconds follows by the EMC Shop Logo screen.

3.2 The EMC Shop Screen



Figure 3.0, the EMC Shop Logo Screen

The EMC Shop, LLC Innovations logo screen it is only displayed for a few seconds and is shown in above.

3.3 Information Screen

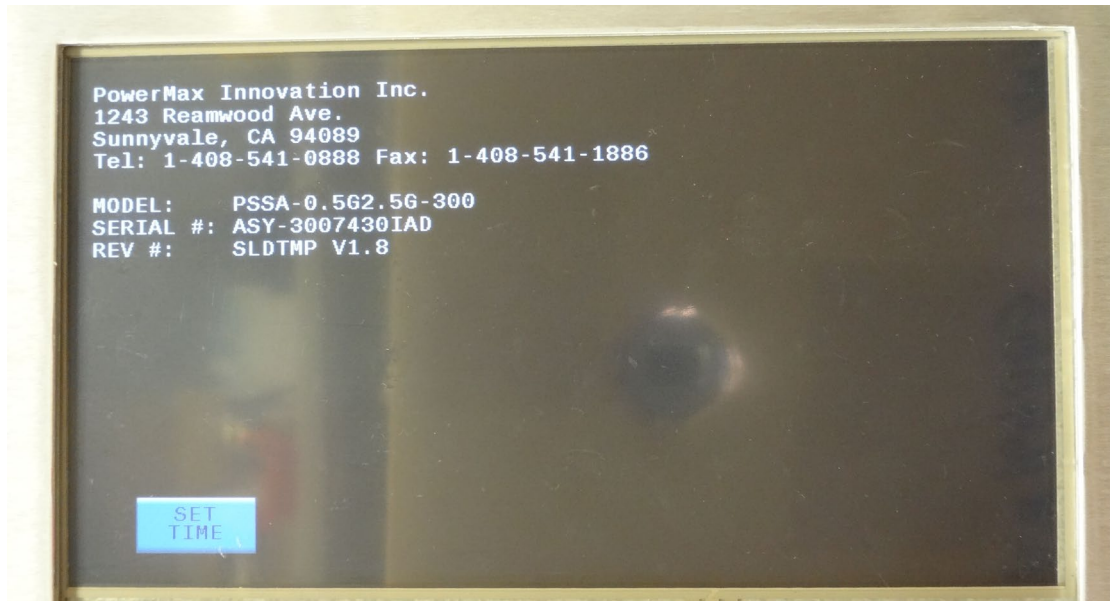

Figure 4.0, System Information and Set Time Button Screen

The Information screen displayed is the set time, Model and version description screen, it will be displayed for a few seconds, should the set time icon be touched the adjust time and date screen will be shown as in Fig. 5.

3.4 Time & Date setup menu

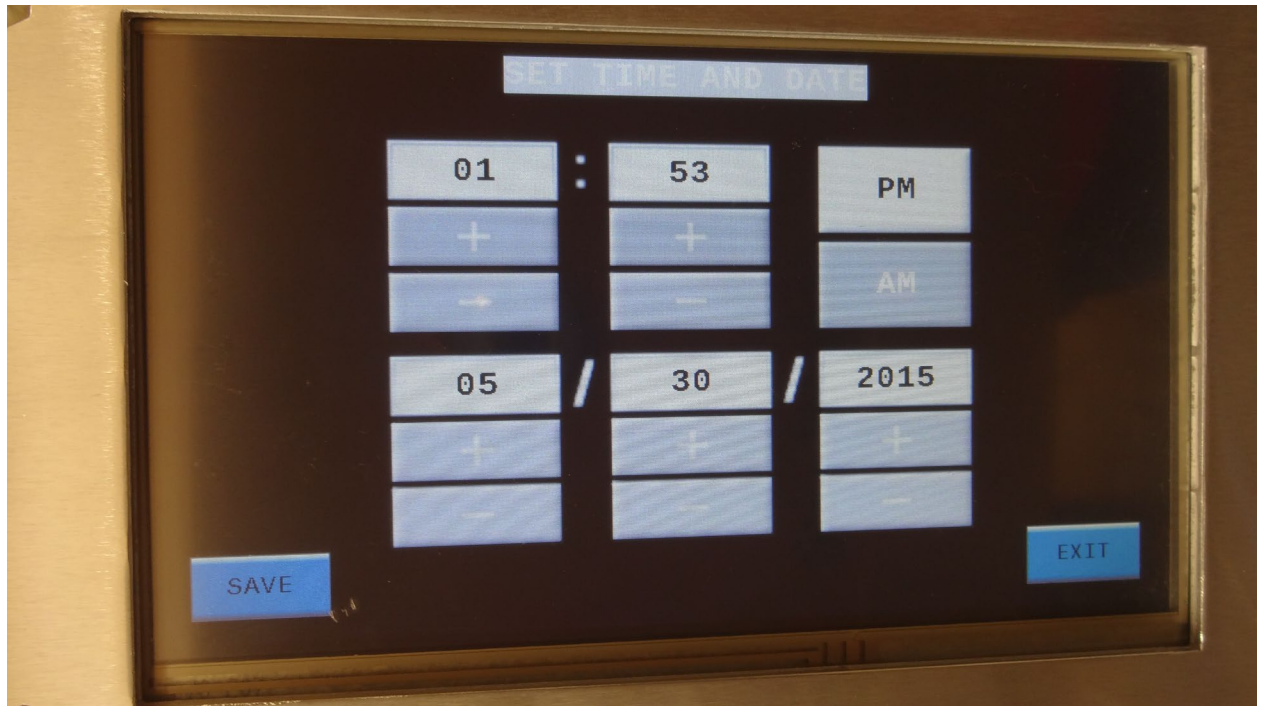

Figure 5.0, Set Time and Date Screen

Figure 5 shows the buttons for adjusting the time and date. Touch the + or – Buttons to adjust the time and date, then save, then exit to return to the main screen.

3.5 Operate Menu, RF-OFF [STANDBY]

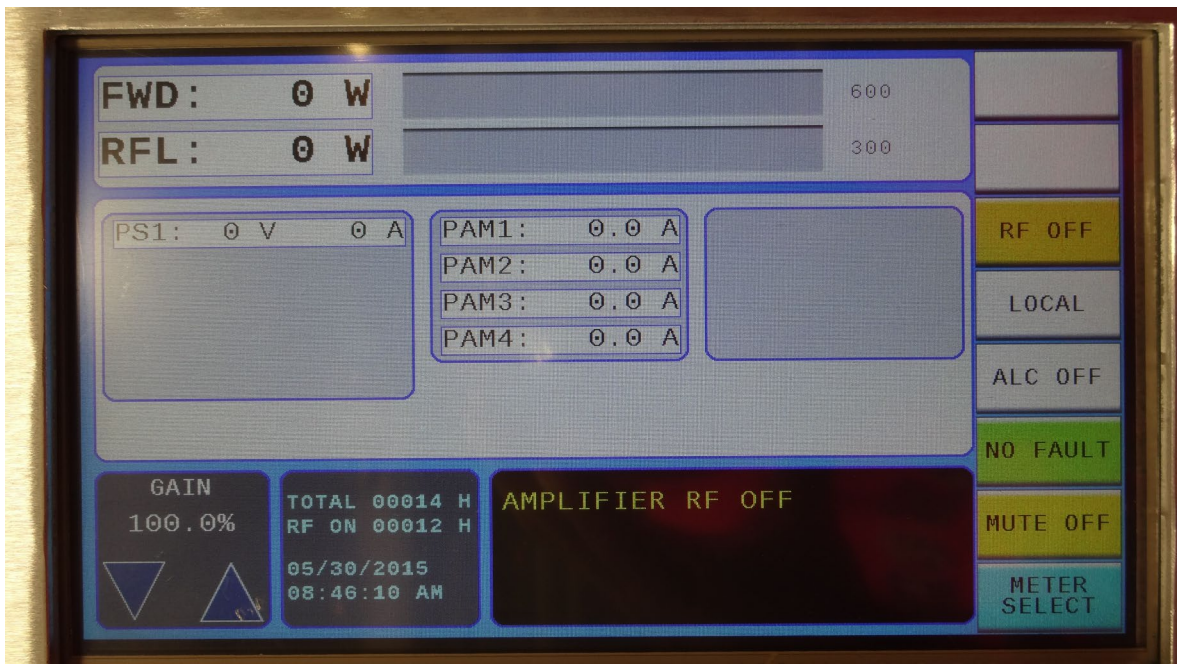

Figure 6.0, OPERATE MENU

The operating menu, will come up in RF OFF-Mode. The values for Forward Power (FWD), Reflected Power (RFL), and metering should be zero. The Gain will be at 100% at all times unless the Attenuator is being controlled by pressing the Gain buttons Up or Down.

3.6 TURNING-ON THE AMPLIFIER

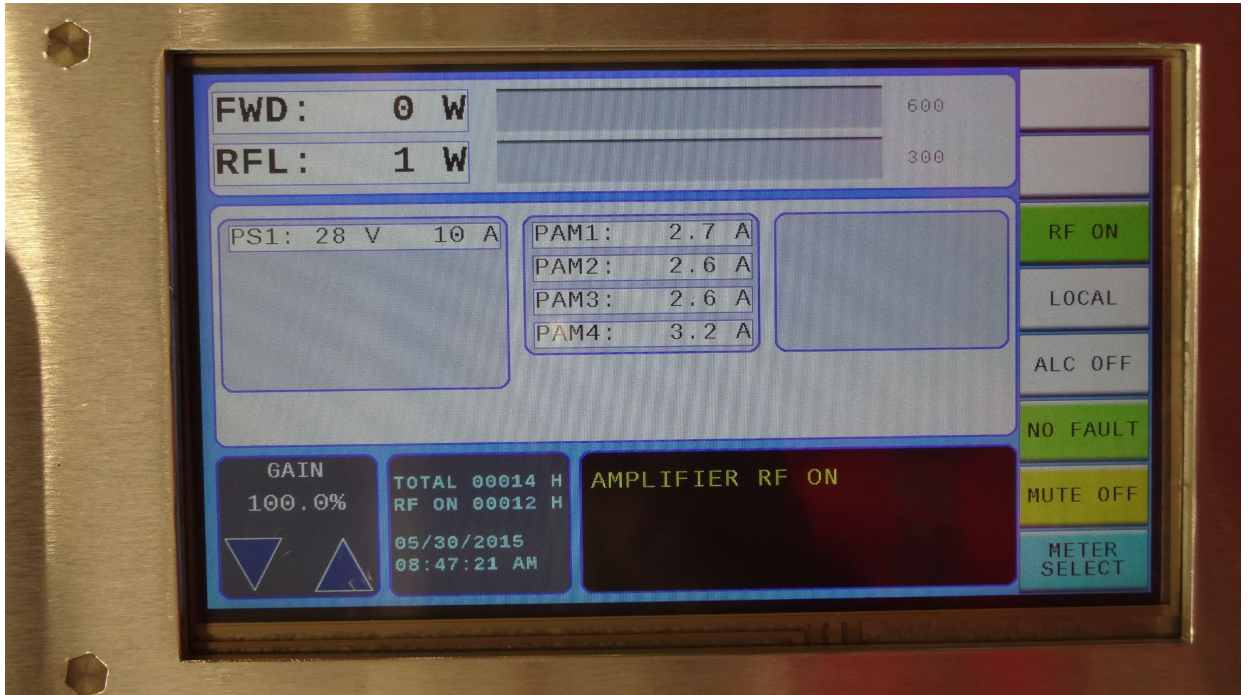

FIGURE 7.0, TURNING ON THE AMPLIFIER

1. Place the unit in RF ON mode. In this mode the Amplifier main DC power supply is turned on and the RF Modules [number of modules used depends on the amplifier type] are biased.
2. The display will show the PS Voltage & current and also the modules [number of modules used depends on the amplifier type] current per operating data sheet (enclosed in the manual).

3.6.1 RF-ON Mode w/RF-Power

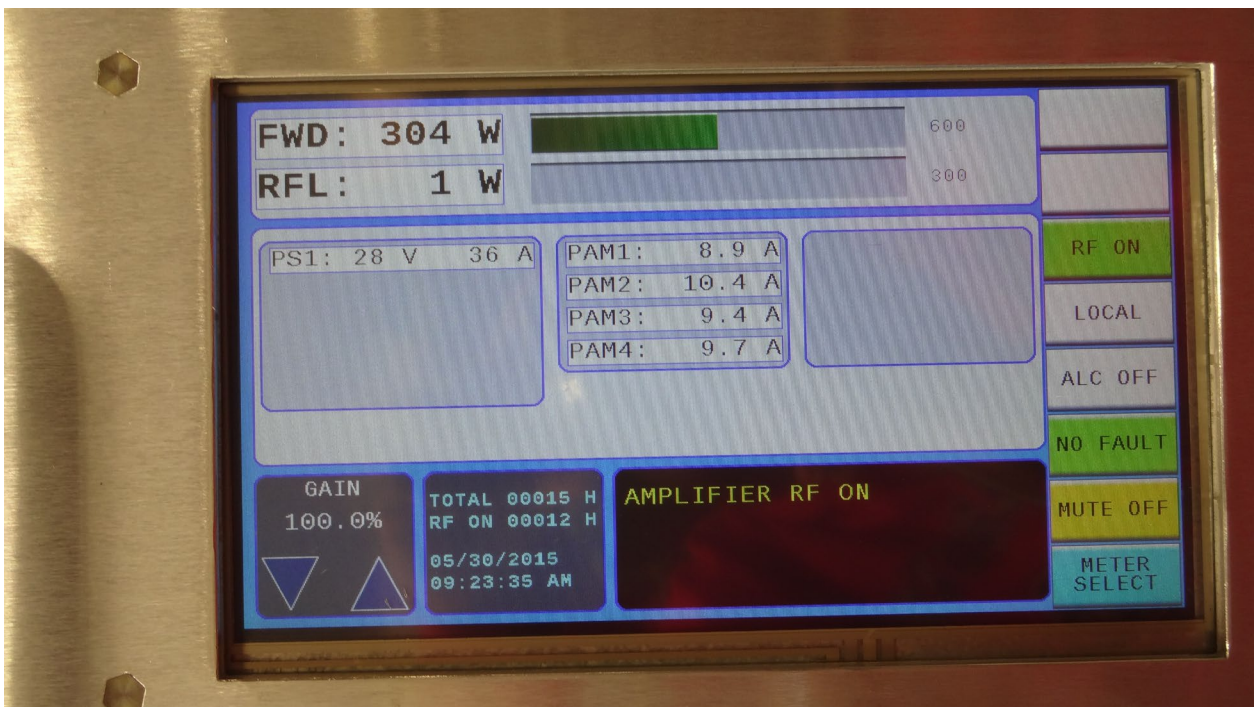

FIGURE 8.0, RF-ON MODE

3. Place the unit in RF ON mode. In this mode the RF Modules are biased.
4. The display will show the RF Output power as the drive power is increased and also shows the RF modules current when driven with RF.

SECTION 4.0

GENERAL INFORMATION

4.1 SCOPE OF THIS MANUAL

This manual is intended to inform a qualified transmitter operator or technician of the normal operating and maintenance procedures for this Amplifier. It is not intended to be a course of instruction for unqualified personnel.

4.2 OPERATION OVERVIEW

The Amplifier is designed to amplify a low level microwave signal and supply a high power CW output. The Amplifier system function is accomplished primarily through the use of a combined High Power RF Modules, control circuitry and power supplies, which can be controlled either locally or remotely. The control circuitry and the power supplies are mounted on the top deck. All the RF components which include the divider, combiner, couplers and High Power RF modules are mounted on a heat sink on the bottom deck.

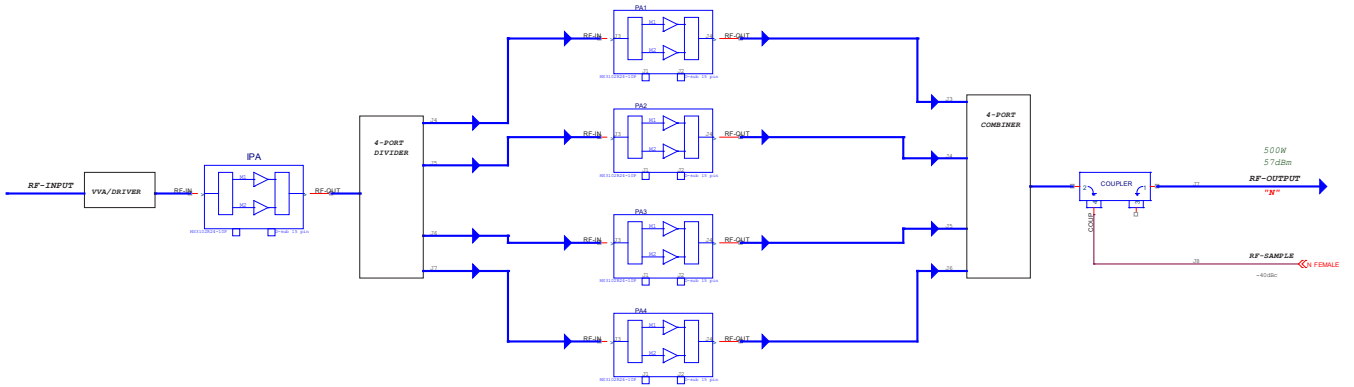

FIGURE 9.0, SYSTEM BLOCK DIAGRAM

4.4 GENERAL SPECIFICATIONS

The specifications listed below represent the minimum performance characteristics at the time of delivery.

SPECIFICATIONS

Frequency Response	10 to 250 MHz
Power Output:	Minimum 1000 Watts
Power Gain:	60 dB min.
Input Impedance:	Nominal 50 Ohms
Output Impedance:	Nominal 50 Ohms
Input Signal Levels:	< 0 dBm (1.0 mW) See data sheet for RF input drive levels
Duty Factor:	CW
Prime Power:	110/208VAC, 50/60 Hz, 3 Phase, 5 Wires
Power Requirements:	≤ 4.5KVA

4.4.1 Functional Description

The required voltages and currents to operate the amplifier are provided by the main 28VDC supply. The primary control circuitry and the service power supplies (+5V, +/- 12V, + 24V) and also the main 28V power supply are energized when the main circuit breaker is turned ON. Upon pressing the RF ON switch, the RF Modules are enabled and biased. At this stage when RF power drive is applied to the RF-Input connector the RF power will be amplified and will be displayed on the TFT display.

4.5 PROTECTION CIRCUITS

The SOLID STATE Amplifier is designed with a variety of protection circuits to provide safeguards for the amplifier should any adverse electrical conditions occur or if the amplifier is accidentally experiencing operator deviation of the design application. Listed below are the safeguards.

4.5.1 Over Heat Protection

The SOLID STATE critical components of this Amplifier is mounted to a heat sink which in turn, air cooled by high efficiency blower. Should an over heating condition occur, either through component failure or by a restricted air flow, the Amplifier contains heat sensors that will shut down the system should an over heating condition occur. As a result, the air inlet and outlet openings should be free of obstructions for proper cooling of the amplifier. Operation is restored by the Fault/Reset button when the amplifier cools to normal temperature levels.

4.5.2 PA Modules Over temperature Fault

The PA modules have internal temperature monitoring which is displayed on the Color display [the display will only show the temperature of # of modules used]. If the temperature in any modules rises above the set limit the amplifier will revert to Standby and the Fault Indication on the front panel Display of the Amplifier will display the related fault.

4.5.3 Mismatch Protection

The Amplifier is designed to operate with a tuned 50 Ohm load and should any mismatching of the 50 Ohm occur the Reverse Power, also called Reflective Power, will increase producing a high VSWR. The Amplifier microprocessor monitors the Reverse Power levels by utilizing a Dual Directional Coupler. When the Reflected Power exceeds 25% the Amplifier Output Power it will go to STBY and the High VSWR message will be indicate on the TFT display. The Reverse Power is also displayed on the TFT Display for operator monitoring for any mismatched load.

4.6 STATUS INDICATORS, CONTROLS AND CONNECTORS

The Amplifier has various controls and status indicators which are identified below and can be visually located on Figure 1.0, Illustration and Figure 3.0, Rear Panel Illustration. A narrative description for the function and purpose of each control and status indicator is provided within paragraphs 4.7.1 and 4.7.2.

RF AMPLIFIER

<u>Front Panel</u>	<u>Rear Panel</u>
Power ON/OFF Ckt Bkr	AC PWR Entry Power Connector
Local/Remote Switch	RJ45 Ethernet Connector
RF ON/OFF Switch	RS 232 Serial port connector
Fault/Reset Switch	RF Output N, Female
TFT Status Display	
RF Input N, Female	
FWD Sample Port N, Female	

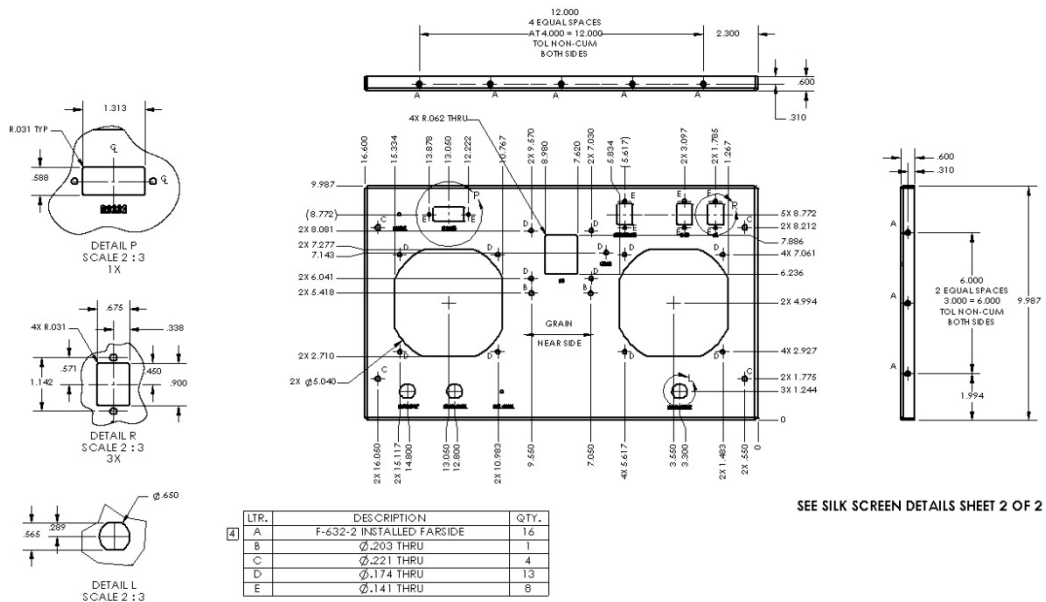

FIGURE 10.0, REAR PANEL ILLUSTRATION

4.6.1 FRONT PANEL STATUS INDICATORS

<u>INDICATOR</u>	<u>FUNCTION</u>
Fault	The Fault will be indicated when the main Power Supply deviate from the design parameters. The Amplifier will revert to RF OFF mode. When either a Thermal condition occurs outside design parameters. Should an excessive temperature condition occur while monitoring the SOLID STATE temperature of the Heat sink temperature the Amplifier will revert to RF OFF mode. Also when an RF module failed. The TFT Display will indicate which fault had occurred.
Total/RFON HOUR	Elapsed time Indication on the TFT display, presents total hours that the amplifier total or RF-ON has been energized.
Remote	The Remote will be indicated when the amplifier is in the remote control mode of operation via the computer.

4.6.2 CONTROLS

<u>CONTROL</u>	<u>FUNCTION</u>
Power ON / OFF	Circuit Breaker to turn On/Off main prime power to the Amplifier.
Local	The Local switch is a momentary switch. When depressed, the amplifier is restored to the local control from the Remote mode of control.
RF OFF / RF ON	Switch, when set to RF ON mode it will apply DC Voltage to the RF Modules, when set to RF OFF it turn RF Modules OFF.
RESET	Switch, when pressed resets Faults.

4.7 TEST DATA SHEETS

Provided with each Amplifier are specific Test Data Sheets measured from the amplifier using a calibrated 50 Ohm Pad to assist the operator in maximizing the performance of the Wide Band Amplifier.

The accuracy of the Metering is $\pm .5$ dB (nominal) so to provide the operator with the ability to maximize the performance of the wide band amplifier.

The Test Data Sheets are located within Appendix A

SECTION 5.0

PRINCIPLES OF OPERATION

5.1 PROPER USAGE AND WARNINGS

5.1.1 Controlling Power Output

With a nominal 50 ohm resistive load and an input signal appropriate to produce a power output within the limitations specified above, the amplifier may be placed in operation. To interrupt the output, simply interrupt the input signal. The amplifier may be run indefinitely at rated output. Output power is usually measured with a power meter and suitable power Termination.

5.1.2 Input Signal Levels

The Amplifier is designed to operate with less than a 0 dBm (1.0 mW) input signal. It is not advisable to over drive any amplifier and depend on protection circuits to maintain proper gain control. The EMC Shop makes available with each shipped amplifier specific data and curves so the operator will know the proper input signal levels to more efficiently operate the amplifier refer to Paragraph 4.7 herein.

5.2.1.1 Preamplifier

The Preamplifier provides the proper drive levels to the RF Modules to obtain the proper Output Power The preamplifier is powered from a low voltage power supply that is independent of the main power supply.

5.2.1.2 Power Amplifier

The Power amplifier consists of the combined high power RF Modules as the main amplification stage. It is powered by 28VDC or 48VDC as the main power supply.

5.2 Pin-Diode Pulse Modulation [Optional]

The amplifier will have a Pin-Diode switch for pulse modulation when this option is selected. The Pulse Input BNC connector is then connected to a pulse generator feeding video pulses with TTL levels. When the Pulse input connector is not connected to any Pulse generator the amplifier will operate normally. When the Pulse Input connector is connected to a pulse generator the RF Input path will open when the Video Input is TTL-High [Isolation] and will reconnect when the Video Input is TTL-Low [Insertion Loss].

SECTION 6.0

REMOTE INTERFACE FOR MEDIUM POWER AMPLIFIERS

6.1 INTRODUCTION

The EMC Shop Amplifiers can be operated remotely from a computer having RS-232 or ETHERNET interfaces. These interfaces will allow the amplifier to be remotely controlled by sending commands to the amplifier. Additionally, the amplifier status and forward and reverse power readings may be read over the remote.

6.2 RS-232 INTERFACE

RS-232, a standard which defines the communication between DTE, data terminal equipment to DCE, data communication equipment. The EMC Shop Amplifiers have a RS-232, serial interface. All amplifier functions can be controlled by coded messages sent over the interface bus via the 9-pin D-type socket connector on the rear panel of the unit.

6.2.1 RS-232 Wiring

Connect the serial port of the amplifier to a computer using a null modem cable or a standard serial cable with a null modem adapter.

<u>Pin #s</u>	<u>Signal Name</u>	<u>Remote Terminal I/O</u>
2	TXD	Output to remote terminal
3	RXD	Input from remote terminal
5	Signal GND	Signal reference

Note: Use the NULL Modem between Computer and Amplifier for RS-232 Interface.

The RS-232 Serial Communication Settings:

Baud Rate:	9600 Baud.
Data Bits:	8
Parity:	None
Stop bits:	1
Flow control:	None

6.3 ETHERNET INTERFACE

The Amplifiers have an Ethernet Interface. All amplifier functions can be controlled by coded messages sent over the interface bus via RJ-45 connector on the rear panel of the unit.

6.3.1 Description

The Ethernet Interface allows the Amplifier to communicate with and participate in a Local Area Network using RJ-45 cable.

The **Internet protocol suite** (commonly **TCP/IP**) is the set of [communications protocols](#) that implement the [protocol stack](#) on which the [Internet](#) and most commercial networks run. It is named for two of the most important protocols in it: the [Transmission Control Protocol](#) (TCP) and the [Internet Protocol](#) (IP), which were also the first two networking protocols defined. Today's IP networking represents a synthesis of two.

TCP/IP uses four numbers to address a computer. Each computer must have a unique four numbers address. The numbers are always between 0 and 255. Addresses are normally written as four numbers separated by a period like this: **192.168.1.50**.

The Ethernet interface is a cable bus which runs over copper or fiber. The copper interfaces use either a coaxial cable or differential twisted pairs. The Ethernet network is defined by IEEE 802.3 standard. Descriptions for each of the physical lines are provided below.

Ethernet Bus 10/100BaseT Pin-Out

Name	Pin	Cable Color	Pin	Name
TX+	1	White/Orange	1	TX+
TX-	2	Orange	2	TX-
RX+	3	White/Green	3	RX+
	4	Blue	4	
	5	White/Blue	5	
RX-	6	Green	6	RX-
	7	White/Brown	7	
	8	Brown	8	

6.3.2 Ethernet Wiring

Connect the RJ-45 port of the amplifier to a computer cable on 100BaseT UTP Cat5 cable.

The EMC Shop uses Lantronix XPort device as an interface to the remote Ethernet. Using a driver provided by Lantronix which is available on <http://www.lantronix.com/device-networking/utilities-tools/device-installer.html> and download Device Installer from there. An IP Address can be read by using Device Installer only when the amplifier and PC are placed in network (on DHCP Server).

6.4 REMOTE COMMAND FORMAT

The EMC Shop Amplifiers remote commands are a string of ASCII characters with the following format:

Command Code	End Of String Characters
--------------	--------------------------

The

Command Code is a three to nine characters command code which the system interprets to determine the type of action to take. See Remote commands below.

NOTES:

1. ALL COMMANDS AND REQUESTS MUST CONSIST ENTIRELY OF UPPER CASE ALPHANUMERIC CHARACTERS.
2. ALL VALUES DISPLAYED DO NOT SHOW THE ZEROS TO THE LEFT OF THE NUMBER VALUE.

6.4.1 Remote/Local Control

When the amplifier receives a command over the remote interface, it is required to enter REMOTE command first to switch into REMOTE operation, entering the LOCAL command or touching the LOCAL button on the front panel returns the unit to normal manual local operation In this option all status commands can be read while the amplifier is into local mode and they should not switch the amplifier into remote mode. An additional LOCAL command is applied to put amp in local mode if it was set for remote operation.

6.4.2 Remote Commands

COMMANDS FOR SSA AMPLIFIER

Command Code	Amplifier Function	Amplifier Response	Description
RF-OFF	Go to RF-OFF Mode	RF-OFF	Brings the amplifier to RF-OFF from RF-ON mode
RF-ON	Go to RF-ON Mode	PS TURN ON	Brings the amplifier to RF-ON from RF-OFF mode
RESET	Fault Reset	RF-OFF	Resets the amplifier if it is in a fault
SETGAINxxx	Sets the gain		Sets the gain percentage number to the xxx

SYSTEM STATUS RESPONSES FOR AMP

Command Code	Amplifier Response	Description
STATUS	OFF	Amplifier Initialization or rebooting
	RF-OFF	Amplifier RF-OFF mode
	RF-ON	Amplifier RF-ON mode
	FAULT	The Amplifier has a Fault
	WARNING	The Amplifier has a warning
STATUSALL	“Model, Warning, Amp status,	Multistate status string
WARNING	Returns warning message	
	WARNING: MDL UNDER CRNT	See the below description
	NO WARNINGS	No warning condition
	WARNING: FWD PWR LIMIT	
	WARNING: RFL PWR LIMIT	
FAULT	Returns Detailed Message	
	HIGH TEMP FAULT	High Temperature fault
	HIGH VSWR FAULT	When VSWR is greater then set value
	PWR SPLY# OVER CURRENT	Current out of Range Warning
	PAM# OVER CURRENT	PA Module at non operating condition
	MODULE UNDER CURRENT	PA Module at non operating condition
	DRIVER OVER CURRENT	Driver at non-operating condition
	DRIVER UNDER CURRENT	Driver at non-operating condition
	IPA# OVER CURRENT	IPA1 at non-operating condition
	IPA# UNDER CURRENT	IPA2 at non-operating condition
	NO FAULTS	No fault condition

POWER AND METERING - STATUS RESPONSES FOR AMP

Command Code	Amplifier Function	Amplifier Response	Description
FWDPWR	Forward Power	'FWD POWER:XXXXXW'	Returns Forward Power Value in Watts
RFLPWR	Reflected Power	'RFL POWER:XXXXXW'	Returns Reflected Power Value in Watts
PS1V	Power Supply 1 Voltage	'PWRSPLYV1: XXXXXV'	Returns PWR Supply Value in Volts,
PS1I	Power Supply 1 Current	'PWRSPLYI1: XXXXXA'	Returns PWR Supply Current in amps
PAMxI	RF PA Module current	'PAM#: XXX.XA'	Returns RF module current in Amps **
IPAIx	RF IPA Module current	'IPAI#: XXX.XA'	Returns RF intermediate module current in Amps **
DRVIx	RF Driver current	'DRVI#: XXX.XA'	Returns RF drive current in Amps **
STBND	Band status	'B#: XXXXXXXXXXXXXXXXXXXX'	Returns band's information with band number and frequency range, **
TEMP-AMB	Amp Ambient Temp	'AMBIENT TEMP: XXXXX C'	Returns Amplifier internal ambient temp
MUTEON	Disables PAs & Driver	'MUTE ON'	**
MUTEOFF	Enables PAs & Driver	'MUTE OFF'	
REMOTE	Put amp in RMT mode	'REMOTE ON'	**
TOTALH	Total Hours	'TOTAL HOURS: XXXXX'	Returns Total Hours
RF-ONH	Total operating hours	'RF ON HOURS: XXXXX'	Returns Operation Hours Value,
ALCOFF	No Leveling	'ALC OFF'	Selects NO Leveling
ALCON	Internal Leveling	'ALC ON'	Selects INTERNAL Leveling
ZEROATT	Zero Attenuation	'GAIN: 100 %'	Sets the Amplifier for ZERO Attenuation
FULLATT	Full Attenuation	'GAIN: 000 %'	Sets the Amplifier for FULL Attenuation
GAIN	Gain Value	'GAIN: XXXXX%'	Returns Gain Value in percentage
MODEL	Model number	'XXXXXXXXXXXXXXXXXX'	Returns Model number of the unit
SN	Serial number	'XXXXXXXXXXXXXXXXXX'	Returns Serial number of the unit
*IDN?	System ID	'EMC,XXXXXXXXXX XXXXX,XXXXXXXXXXXXXXXXXX X,XXXXXXXXXX'	Returns ASCII response comprising of four data fields in the format <Manufacturer>{19 Characters}, <Model>(20 Characters), <Serial Number>(20 Characters), <Firmware Version>(11 Characters)
*RST	Reset Amplifier CPU		Reset Command, Sets the Amplifier to the factory default power up state (reboots MPU)

** When Applicable

6.4.3 REMOTE EXAMPLE CODE

RS-232 or Ethernet, Example using Hyper-terminal

1. Connect serial port of amplifier to computer using a null modem cable or a standard serial cable with a null modem adapter.
2. Use a program such as Hyper-terminal to communicate with the amplifier. (To find Hyper-terminal go to Start → Programs → Accessories → Communications → Hyper Terminal, and click on Hyper terminal.

To setup Hyper terminal follow the directions below.
When Hyper terminal runs a setup dialog box will open:

For RS-232:

- 6.4 Enter a name and choose an icon. Click OK.
- 6.5 In the Connect Using box select your Comm. port (Ex. “Direct to Com1” or “Com1”) for RS-232 or TCP/IP for Ethernet remote. Click OK.
- 6.6 In Bits per Second select “9600”.
- 6.7 In Data Bits select “8”.
- 6.8 In Parity Select “None”.
- 6.9 In Stop bits select “1”.
- 6.10 In Flow control select “None”
- 6.11 Click OK.

For Ethernet:

- 2.1 Enter a name and choose an icon. Click OK.
- 2.2 In the Connect Using box select TCP/IP for Ethernet remote. Click OK.
- 2.3 Enter an **IP Address** in Host Address box and **10001** in Port Number box. Click OK.
3. If you use Hyper-terminal steps 2.1 to 2.8 will set up Com1 to communicate at 9600 baud, 8 bits, and no parity with 1 stop bit and steps 2.1 to 2.3 will set up Ethernet to communicate at 57600 baud.
4. Turn amplifier line power ON.
5. To place the amplifier in remote operation type in a valid command such as “STATUS” and then hit the “Enter” key. The amplifier will then go into remote operation and the status will be displayed on the computer.

See the section **6.4.2 REMOTE COMMANDS** for the list of usable commands and responses.

Hex equivalent of string: 0x4f, 0x50, 0x52, 0x54,0x0d,0x0a

Action: The amplifier will go to RF-ON mode if the amplifier was previously in Standby mode.

Action: None

Example of response: N/A

Hex value of example: N/A

Command to read the amplifiers forward power:

ASCII String to amplifier: POWERFWD(cr)(lf)

Hex equivalent of string: 0x50,0x4f,0x57,0x45,0x52,0x46,0x57,0x44,0x0d,0x0a

Action: None

Response: Responds with the amplifiers forward power reading.

Example of response : POWER FWD: 09005 W(cr)(lf)

Hex value of example response :

0x50,0x4f,0x57,0x45,0x52,0x20,0x46,0x57,0x44,0x3a,0x20,0x30,0x39,0x30,0x30,0x35,0x20,0x57,0x0a,0x0d

SECTION 7.0

MAINTENANCE AND SERVICING

7.1 PERIODIC MAINTENANCE

The only periodic maintenance required on the SOLID STATE amplifier system is insuring that the cooling vents are not obstructed in such a manner that the air flow is restricted. Periodic cleaning of the vents may be required depending on the degree of dust in the atmosphere.

7.2. SERVICING THE AMPLIFIER

Servicing of the amplifier by the operator is not recommended. Most of the internal circuitry requires special and unique test instruments to trouble shoot, align and calibrate the circuits. Should servicing be required, refer to Paragraph 7.3.

7.2.1 TROUBLESHOOTING

PROBLEM	CAUSE	SOLUTION	COMMENTS
TFT display blank	No service voltages	Check line power. Check service voltages, +12VDC, -12VDC, 5VDC	Connect AC line to specified Prime power source. Refer to S/N tag on unit
Amp will not go to Operate mode	Door interlock open, High VSWR	Check that door interlock BNC connector is terminated with either 50 Ohms or short. Check RF output termination connection.	When operating any RF amplifier proper termination must be connected to the RF output connector.
Power supply fault	28VDC or 48VDC Power supply faulty	Check Power voltage output voltage when RF-ON is pressed	Check Enable command controlling PS
Thermal fault	Over-heating	Make sure airflow is adequate and ambient temperature within the limit.	

7.3 EQUIPMENT RETURN PROCEDURE

Should such an event arise that the Amplifier requires repair or calibration, it is recommended that the reader follows the Equipment Return Procedure so the equipment can be repaired or calibrated and returned in an efficient and timely manner.

7.3.1 Request a RMA Number

Contact the EMC Shop Service Department either in writing or by calling 408-541.0888 and request a Return Material Authorization (RMA) Number. The RMA Number is the method the EMC Shop uses to prepare its' services for returned material in transit and acts as a tracking document for the returned material through the repair or calibration process. The RMA also documents the customers' specific instructions or reason related to the return of the material.

7.3.2 Return All Accessories

In the interest of saving time and expediting the repair or calibration process, return all the associated accessories described in Section 1.0 when returning the equipment for repair or calibration. In many cases, a faulty accessory could give an illusion that the equipment itself has failed. For this reason it is important to return the all the accessories with the equipment. It is also the EMC Shop's policy to verify performance of all associated accessories of Section 1.0 before returning the equipment to service.

7.3.3 Packaging The Equipment

When returning equipment to the manufacturer, always wrap each accessory separately and provide sufficient protective material around each item to prevent damage from handling and shipping conditions.

7.3.4 Reference The RMA Number

As detailed in Paragraph 7.3.1, always reference the EMC Shop assigned RMA Number on your Packing List and Purchase Order and also when any inquiries are made.

SECTION 8.0

WARRANTY INFORMATION

© **The EMC Shop, LLC (EMC)** warrants each product of its manufacture to be free from any defect in material and workmanship for a period of (1) One year from the date of shipment unless otherwise specified with the purchase order. All warranty returns, however, must first be authorized by our factory office representative. Refer to the Service Section for information on how to return items for warranty repair.

Warranty liability shall be limited to repair or replacement of, or part thereof, which proves to be defective after inspection by the EMC Shop. This warranty shall not apply to any the EMC Shop product that has been disassembled, modified, physically or electrically damaged or any product that has been subjected to conditions exceeding the applicable specifications or ratings.

The EMC Shop shall not be liable for any direct or consequential injury, loss, or damage incurred through the use, or the inability to use any the EMC Shop product.

The EMC Shop reserves the right to make changes to any the EMC Shop product without incurring any obligation to make the same changes to previously purchased units.

This warranty is the full extent of obligation and liability assumed by the EMC Shop with respect to any and all the EMC Shop products. The EMC Shop neither makes, nor authorizes any person to make any other guarantee or warranty concerning the EMC Shop products.

APPENDIX A

TEST DATA SHEETS

**APPENDIX B
Drawings Package**

Bill of Materials (BOM)