

# Keysight 33210A 10 MHz Function/Arbitrary Waveform Generator

# Notices

## Copyright Notice

© Keysight Technologies 2008 - 2017  
No part of this manual may be reproduced in any form or by any means (including electronic storage and retrieval or translation into a foreign language) without prior agreement and written consent from Keysight Technologies as governed by United States and international copyright laws.

## Manual Part Number

33210-90010

## Edition

Edition 2, October 1, 2017

## Printed in:

Printed in Malaysia

## Published by:

Keysight Technologies  
Bayan Lepas Free Industrial Zone,  
11900 Penang, Malaysia

## Technology Licenses

The hardware and/or software described in this document are furnished under a license and may be used or copied only in accordance with the terms of such license.

## Declaration of Conformity

Declarations of Conformity for this product and for other Keysight products may be downloaded from the Web. Go to <http://www.keysight.com/go/conformity>. You can then search by product number to find the latest Declaration of Conformity.

## U.S. Government Rights

The Software is “commercial computer software,” as defined by Federal Acquisition Regulation (“FAR”) 2.101. Pursuant to FAR 12.212 and 27.405-3 and Department of Defense FAR Supplement (“DFARS”) 227.7202, the U.S. government acquires commercial computer software under the same terms by which the software is customarily provided to the public. Accordingly, Keysight provides the Software to U.S. government customers under its standard commercial license, which is embodied in its End User License Agreement (EULA), a copy of which can be found at <http://www.keysight.com/find/sweula>. The license set forth in the EULA represents the exclusive authority by which the U.S. government may use, modify, distribute, or disclose the Software. The EULA and the license set forth therein, does not require or permit, among other things, that Keysight: (1) Furnish technical information related to commercial computer software or commercial computer software documentation that is not customarily provided to the public; or (2) Relinquish to, or otherwise provide, the government rights in excess of these rights customarily provided to the public to use, modify, reproduce, release, perform, display, or disclose commercial computer software or commercial computer software documentation. No additional government requirements beyond those set forth in the EULA shall apply, except to the extent that those terms, rights, or licenses are explicitly required from all providers of commercial computer software pursuant to the FAR and the DFARS and are set forth specifically in writing elsewhere in the EULA. Keysight shall be under no obligation to update, revise or otherwise modify the Software. With respect to any technical data as defined by FAR 2.101, pursuant to FAR 12.211 and 27.404.2 and DFARS 227.7102, the U.S. government acquires no greater than Limited Rights as defined in FAR 27.401 or DFAR 227.7103-5 (c), as applicable in any technical data.

## Warranty

THE MATERIAL CONTAINED IN THIS DOCUMENT IS PROVIDED “AS IS,” AND IS SUBJECT TO BEING CHANGED, WITHOUT NOTICE, IN FUTURE EDITIONS. FURTHER, TO THE MAXIMUM EXTENT PERMITTED BY APPLICABLE LAW, KEYSIGHT DISCLAIMS ALL WARRANTIES, EITHER EXPRESS OR IMPLIED, WITH REGARD TO THIS MANUAL AND ANY INFORMATION CONTAINED HEREIN, INCLUDING BUT NOT LIMITED TO THE IMPLIED WARRANTIES OF MERCHANTABILITY AND FITNESS FOR A PARTICULAR PURPOSE. KEYSIGHT SHALL NOT BE LIABLE FOR ERRORS OR FOR INCIDENTAL OR CONSEQUENTIAL DAMAGES IN CONNECTION WITH THE FURNISHING, USE, OR PERFORMANCE OF THIS DOCUMENT OR OF ANY INFORMATION CONTAINED HEREIN. SHOULD KEYSIGHT AND THE USER HAVE A SEPARATE WRITTEN AGREEMENT WITH WARRANTY TERMS COVERING THE MATERIAL IN THIS DOCUMENT THAT CONFLICT WITH THESE TERMS, THE WARRANTY TERMS IN THE SEPARATE AGREEMENT SHALL CONTROL.

## Safety Information

### CAUTION

A CAUTION notice denotes a hazard. It calls attention to an operating procedure, practice, or the like that, if not correctly performed or adhered to, could result in damage to the product or loss of important data. Do not proceed beyond a CAUTION notice until the indicated conditions are fully understood and met.

### WARNING

A WARNING notice denotes a hazard. It calls attention to an operating procedure, practice, or the like that, if not correctly performed or adhered to, could result in personal injury or death. Do not proceed beyond a WARNING notice until the indicated conditions are fully understood and met.

## Keysight 33210A at a Glance

The Keysight Technologies 33210A is a 10 MHz synthesized function generator with built-in arbitrary waveform and pulse capabilities. Its combination of bench-top and system features makes this function generator a versatile solution for your testing requirements now and in the future.

### **Convenient bench-top features**

- Up to 10 standard waveforms
- Built-in 14-bit 50 MSa/s waveform capability
- Precise pulse waveform capabilities with adjustable edge time
- LCD display provides numeric and graphical views
- Easy-to-use knob and numeric keypad
- Instrument state storage with user-defined names
- Portable, ruggedized case with non-skid feet

### **Flexible system features**

- Four optional downloadable 8K-point arbitrary waveform memories (Option 002)
- GPIB (IEEE-488), USB, and LAN remote interfaces are standard
- LXI Class C Compliant
- SCPI (Standard Commands for Programmable Instruments) compatibility

#### **NOTE**

Unless otherwise indicated, this manual applies to all Serial Numbers.

---

## The Front Panel at a Glance

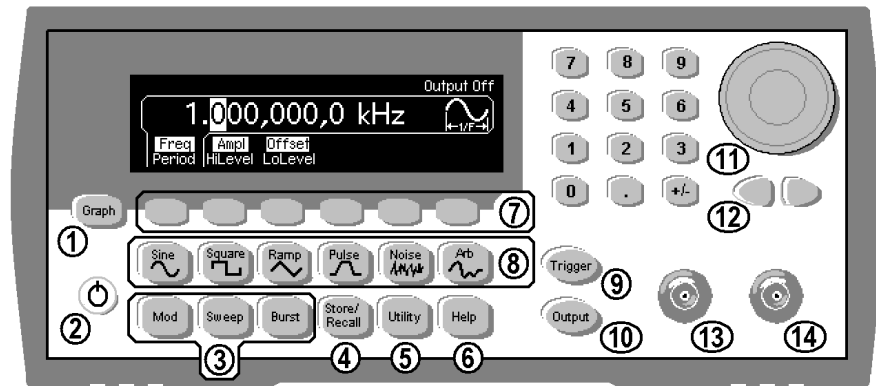

- |                               |   |
|-------------------------------|---|
| 1 Graph Mode/Local Key        | 9 Manual Trigger Key ( <i>used for Sweep and Burst only</i> ) |
| 2 On/Off Switch               | 10 Output Enable/Disable Key                                  |
| 3 Modulation/Sweep/Burst Keys | 11 Knob   |
| 4 State Storage Menu Key      | 12 Cursor Keys  |
| 5 Utility Menu Key            | 13 Sync Connector   |
| 6 Help Menu Key               | 14 Output Connector   |
| 7 Menu Operation Softkeys     |   |
| 8 Waveform Selection Keys     |   |

### NOTE

To get context-sensitive help on any front-panel key or menu softkey, press and hold down that key.

# The Front-Panel Display at a Glance

## Menu Mode

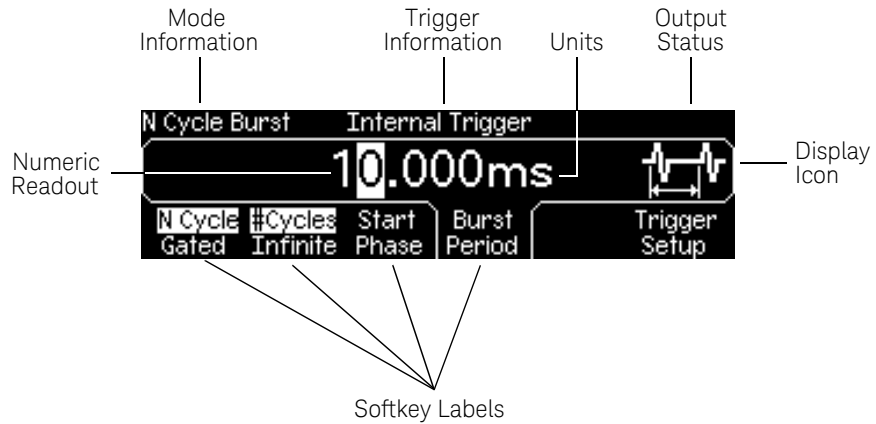

## Graph Mode

To enter or exit the Graph Mode, press the **Graph** key.

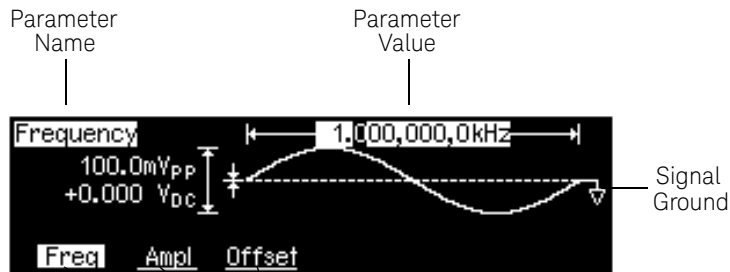

In Graph Mode, only one parameter label is displayed for each key at one time.

## Front-Panel Number Entry

You can enter numbers from the front-panel using one of two methods.

### Use the knob and cursor keys to modify the displayed number.

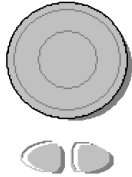

- 1 Use the keys below the knob to move the cursor left or right.
- 2 Rotate the knob to change a digit (clockwise to increase).

### Use the keypad to enter numbers and the softkeys to select units.



- 1 Key in a value as you would on a typical calculator.
- 2 Select a unit to enter the value.



## The Rear Panel at a Glance

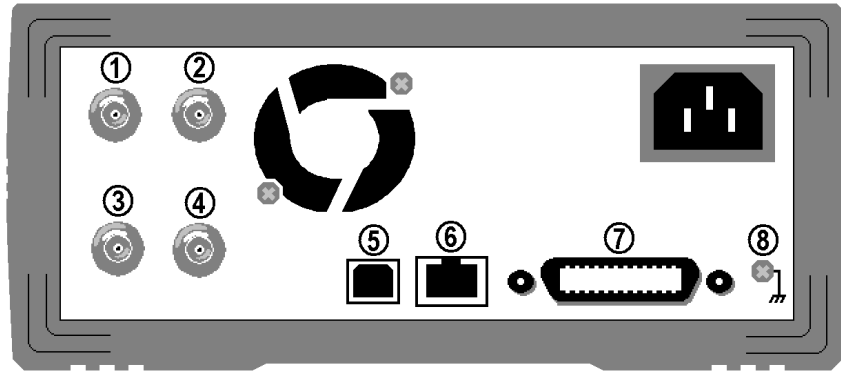

- |  |   |
|--|---|
| 1 External 10 MHz Reference Input Terminal (Option 001 only).  | 4 Input: External Trigger/Burst Gate Output: Trigger Output |
| 2 Internal 10 MHz Reference Output Terminal (Option 001 only). | 5 USB Interface Connector                                   |
| 3 External Modulation Input Terminal                           | 6 LAN Interface Connector                                   |
|  | 7 GPIB Interface Connector                                  |
|  | 8 Chassis Ground  |

### Use the **Utility** menu to:

- Select the GPIB address (see [Chapter 3](#)).
- Set the network parameters for the LAN interface (see [Chapter 3](#)).
- Display the current network parameters (see [Chapter 3](#)).

### NOTE

The External and Internal 10 MHz Reference Terminals (1 and 2, above) are present **only** if Option 001, External Timebase Reference, is installed. Otherwise, the holes for these connectors are plugged.

**WARNING**

For protection from electrical shock, the power cord ground must not be defeated. If only a two-contact electrical outlet is available, connect the instrument's chassis ground screw (see above) to a good earth ground.

---



## In This Book

**Specifications** Chapter 1 lists the function generator's specifications.

**Quick Start** Chapter 2 prepares the function generator for use and helps you get familiar with a few of its front-panel features.

**Front-Panel Menu Operation** Chapter 3 introduces you to the front-panel menu and describes some of the function generator's menu features.

**Calibration Procedures** Chapter 4 provides calibration, verification, and adjustment procedures for the function generator.

**Block Diagram** Chapter 5 describes block and power supply operation of the function generator.

**Disassembly and Repair** Chapter 6 provides guidelines for returning your function generator to Keysight Technologies for servicing, or for servicing it yourself. This chapter also contains a list of replaceable parts for the function generator and how to order the parts.

**Backdating** Chapter 7 describes the differences between this manual and older issues of this manual.

## Waste Electrical and Electronic Equipment (WEEE) Directive

This instrument complies with the WEEE Directive marking requirement. This affixed product label indicates that you must not discard this electrical or electronic product in domestic household waste.

### Product category:

With reference to the equipment types in the WEEE directive Annex 1, this instrument is classified as a “Monitoring and Control Instrument” product.

The affixed product label is as shown below.



Do not dispose in domestic household waste.

To return this unwanted instrument, contact your nearest Keysight Service Center, or visit <http://about.keysight.com/en/companyinfo/environment/takeback.shtml> for more information.

## Sales and Technical Support

To contact Keysight for sales and technical support, refer to the support links on the following Keysight websites:

- [www.keysight.com/find/33210A](http://www.keysight.com/find/33210A)  
(product-specific information and support, software and documentation updates)
- [www.keysight.com/find/assist](http://www.keysight.com/find/assist)  
(worldwide contact information for repair and service)

# Table of Contents

Keysight 33210A at a Glance	3
The Front Panel at a Glance	4
The Front-Panel Display at a Glance	5
Menu Mode	5
Graph Mode	5
Front-Panel Number Entry	6
The Rear Panel at a Glance	7
In This Book	9
Waste Electrical and Electronic Equipment (WEEE) Directive	10
Product category:	10
Sales and Technical Support	10
<b>1 Specifications</b>	
<b>2 Quick Start</b>	
Introduction	18
To Prepare the Function Generator for Use	19
To Adjust the Carrying Handle	20
To Set the Output Frequency	21
To Set the Output Amplitude	22
To Set a DC Offset Voltage	24
To Set the High-Level and Low-Level Values	25
To Select “DC Volts”	26
To Set the Duty Cycle of a Square Wave	27
To Configure a Pulse Waveform	28
To View a Waveform Graph	29
To Output a Stored Arbitrary Waveform	30
To Use the Built-In Help System	31
To Rack Mount the Function Generator	33

<b>3</b>	<b>Front-Panel Menu Operation</b>	
	Introduction	36
	Front-Panel Menu Reference	37
	To Select the Output Termination	41
	To Reset the Function Generator	42
	To Read the Calibration Information	43
	To Unsecure and Secure for Calibration	44
	To Unsecure for Calibration	45
	To Secure After Calibration	46
	To Store the Instrument State	47
	To Configure the Remote Interface	48
	GPIB Configuration	48
	USB Configuration	48
	LAN Configuration	49
<b>4</b>	<b>Calibration Procedures</b>	
	Introduction	57
	Keysight Technologies Calibration Services	58
	Calibration Interval	58
	Adjustment is Recommended	59
	Time Required for Calibration	60
	Automating Calibration Procedures	61
	Recommended Test Equipment	62
	Test Considerations	63
	Performance Verification Tests	64
	Self-Test	64
	Quick Performance Check	65
	Performance Verification Tests	65
	Internal Timebase Verification	68
	AC Amplitude (high-impedance) Verification	69
	Low Frequency Flatness Verification	71

0 dB Range Flatness Verification	72
+10 dB Range Flatness Verification	74
+20 dB Range Flatness Verification	76
Calibration Security	78
To Unsecure the Instrument Without the Security Code	78
Calibration Message	80
Calibration Count	81
General Calibration/Adjustment Procedure	82
Aborting a Calibration in Progress	83
Sequence of Adjustments	84
Self-Test	85
Frequency (Internal Timebase) Adjustment	86
Internal ADC Adjustment/Self Calibration	88
Output Impedance Adjustment	90
AC Amplitude (high-impedance) Adjustment	92
Low Frequency Flatness Adjustment	94
0 dB Range Flatness Adjustments	96
+10 dB Range Flatness Adjustments	98
+20 dB Range Flatness Adjustment	100
Calibration Errors	103
<b>5 Block Diagram</b>	
Introduction	106
Block Diagram	107
Power Supplies	110
<b>6 Disassembly and Repair</b>	
Service	112
Operating Checklist	113
Is the instrument inoperative?	113
Is the display working?	113

Does the instrument fail self-test? .....	113
Types of Service Available .....	114
Extended Service Contracts .....	114
Obtaining Repair Service (Worldwide) .....	114
Repackaging for Shipment .....	115
Cleaning .....	115
Electrostatic Discharge (ESD) Precautions .....	116
Surface Mount Repair .....	116
Troubleshooting Hints .....	117
Unit is Inoperative .....	117
Is the display working? .....	117
Unit Fails Self-Test .....	117
Power Supply .....	118
Self-Test Procedures .....	119
Power-On Self-Test .....	119
Complete Self-Test .....	119
Self-Tests .....	120
Mechanical Disassembly .....	122
General Disassembly Procedure .....	123
Removing the Main Power Supply Assembly .....	127
Front-Panel Removal Procedure .....	128
Front-Panel Disassembly .....	131
External Timebase Circuit Board Disassembly .....	134
Replaceable Parts .....	135
To Order Replaceable Parts .....	135
Parts List .....	135
<b>7 Backdating</b>	
Index .....	139

# 1 Specifications

For the specifications and characteristics of the 33210A 10 MHz Function/  
Arbitrary Waveform Generator, refer to the datasheet at  
<http://literature.cdn.keysight.com/litweb/pdf/5989-8926EN.pdf>

THIS PAGE HAS BEEN INTENTIONALLY LEFT BLANK.



## 2 Quick Start

Introduction	18
To Prepare the Function Generator for Use	19
To Adjust the Carrying Handle	20
To Set the Output Frequency	21
To Set the Output Amplitude	22
To Set a DC Offset Voltage	24
To Set the High-Level and Low-Level Values	25
To Select “DC Volts”	26
To Set the Duty Cycle of a Square Wave	27
To Configure a Pulse Waveform	28
To View a Waveform Graph	29
To Output a Stored Arbitrary Waveform	30
To Use the Built-In Help System	31
To Rack Mount the Function Generator	33

## Introduction

One of the first things to do with your function generator is to become acquainted with the front panel. We have written the exercises in this chapter to prepare the instrument for use and help you get familiar with some of its front-panel operations. This chapter is divided into the following sections:

- [To Prepare the Function Generator for Use](#) *on page 19*
- [To Adjust the Carrying Handle](#) *on page 20*
- [To Set the Output Frequency](#) *on page 21*
- [To Set the Output Amplitude](#) *on page 22*
- [To Set a DC Offset Voltage](#) *on page 24*
- [To Set the High-Level and Low-Level Values](#) *on page 25*
- [To Select “DC Volts”](#) *on page 26*
- [To Set the Duty Cycle of a Square Wave](#) *on page 27*
- [To Configure a Pulse Waveform](#) *on page 28*
- [To View a Waveform Graph](#) *on page 29*
- [To Output a Stored Arbitrary Waveform](#) *on page 30*
- [To Use the Built-In Help System](#) *on page 31*
- [To Rack Mount the Function Generator](#) *on page 33*

## To Prepare the Function Generator for Use

### 1 Check the list of supplied items.

Verify that you have received the following items with your instrument. If anything is missing, please contact your nearest Keysight Sales Office.

- Power cord (for country of destination).
- Certificate of Calibration.
- *Keysight 33210A Product Reference CD* (product software, programming examples, and manuals).
- *Keysight Automation-Ready CD* (Keysight IO Libraries Suite).
- USB 2.0 cable.

#### NOTE

All of the 33210A product documentation is provided on the Keysight 33210A Product Reference CD that comes with the product, and is also available on the Web at [www.keysight.com/find/33210A](http://www.keysight.com/find/33210A). Printed (hardcopy) manuals are available as an extra cost option.



Power  
Switch

### 2 Connect the power cord and turn on the function generator.

The instrument runs a short power-on self test, which takes a few seconds. When the instrument is ready for use it displays a message about how to obtain help, along with the current GPIB address and USB identification string. The function generator powers up in the *sine wave* function at 1 kHz with an amplitude of 100 mV peak-to-peak (into a 50Ω termination). At power-on, the *Output* connector is disabled. To enable the *Output* connector, press the  key.

If the function generator *does not* turn on, verify that the power cord is firmly connected to the power receptacle on the rear panel (the power-line voltage is automatically sensed at power-on). You should also make sure that the function generator is connected to a power source that is energized. Then, verify that the function generator is turned on.

#### NOTE

If the power-on self test fails, “Self-Test Failed” is displayed along with an error code. See the *Keysight 33210A Service Guide* for information on error codes, and for instructions on returning the function generator to Keysight for service.

## To Adjust the Carrying Handle

To adjust the position, grasp the handle by the sides and *pull outward*. Then, rotate the handle to the desired position.

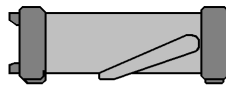

**Retracted**

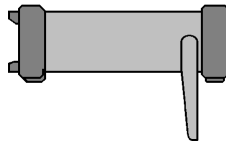

**Extended**

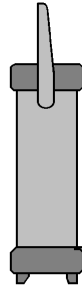

**Carrying  
Position**

## To Set the Output Frequency

At power-on, the function generator outputs a sine wave at 1 kHz with an amplitude of 100 mV peak-to-peak (into a 50 $\Omega$  termination). *The following steps show you how to change the frequency to 1.2 MHz.*

### 1 Press the “Freq” softkey.

The displayed frequency is either the power-on value or the frequency previously selected. When you change functions, the same frequency is used if the present value is valid for the new function. To set the waveform *period* instead, press the **Freq** softkey again to toggle to the **Period** softkey (the current selection is highlighted).



### 2 Enter the magnitude of the desired frequency.

Using the numeric keypad, enter the value “1.2”.



### 3 Select the desired units.

Press the softkey that corresponds to the desired units. When you select the units, the function generator outputs a waveform with the displayed frequency (if the output is enabled). For this example, press **MHz**.



#### NOTE

You can also enter the desired value using the knob and cursor keys.

## To Set the Output Amplitude

At power-on, the function generator outputs a sine wave with an amplitude of 100 mV peak-to-peak (into a 50 $\Omega$  termination). *The following steps show you how to change the amplitude to 50 mVrms.*

### 1 Press the “Ampl” softkey.

The displayed amplitude is either the power-on value or the amplitude previously selected. When you change functions, the same amplitude is used if the present value is valid for the new function. To set the amplitude using a *high level* and *low level*, press the **Ampl** softkey again to toggle to the **HiLevel** and **LoLevel** softkeys (the current selection is highlighted).



### 2 Enter the magnitude of the desired amplitude.

Using the numeric keypad, enter the value “50”.



### 3 Select the desired units.

Press the softkey that corresponds to the desired units. When you select the units, the function generator outputs the waveform with the displayed amplitude (if the output is enabled). For this example, press **mV<sub>RMS</sub>**.



#### NOTE

You can also enter the desired value using the knob and cursor keys.

You can easily convert the displayed amplitude from one unit to another. For example, the following steps show you how to convert the amplitude from  $V_{rms}$  to  $V_{pp}$ .

#### 4 Enter the numeric entry mode.

Press the  $\pm$  key to enter the numeric entry mode.

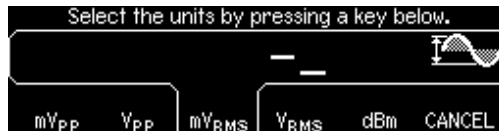

#### 5 Select the new units.

Press the softkey that corresponds to the desired units. The displayed value is converted to the new units. For this example, press the **Vpp** softkey to convert 50 mVrms to its equivalent in volts peak-to-peak.



To change the displayed amplitude by *decades*, press the right-cursor key to move the cursor to the units on the right side of the display. Then, rotate the knob to increase or decrease the displayed amplitude by decades.



## To Set a DC Offset Voltage

At power-on, the function generator outputs a sine wave with a dc offset of 0 volts (into a  $50\Omega$  termination). *The following steps show you how to change the offset to  $-1.5\text{ mVdc}$ .*

### 1 Press the “Offset” softkey.

The displayed offset voltage is either the power-on value or the offset previously selected. When you change functions, the same offset is used if the present value is valid for the new function.



### 2 Enter the magnitude of the desired offset.

Using the numeric keypad, enter the value “ $-1.5$ ”.



### 3 Select the desired units.

Press the softkey that corresponds to the desired units. When you select the units, the function generator outputs the waveform with the displayed offset (if the output is enabled). For this example, press  $\text{mV}_{DC}$ .



#### NOTE

You can also enter the desired value using the knob and cursor keys.



## To Set the High-Level and Low-Level Values

You can specify a signal by setting its amplitude and dc offset values, as described previously. Another way to set the limits of a signal is to specify its high-level (maximum) and low-level (minimum) values. This is typically convenient for digital applications. In the following example, let's set the high-level to 1.0 V and the low-level to 0.0 V.

- 1 Press the “Ampl” softkey to select “Ampl”.
- 2 Press the softkey again to toggle to “HiLevel”.

Note that both the **Ampl** and **Offset** softkeys toggle together, to **HiLevel** and **LoLevel**, respectively.



- 3 Set the “HiLevel” value.

Using the numeric keypad or the knob, select a value of “1.0 V”. (If you are using the keypad, you will need to select the unit, “V”, to enter the value.)



- 4 Press the “LoLevel” softkey and set the value.

Again, use the numeric keypad or the knob to enter a value of “0.0 V”.



Note that these settings (high-level = “1.0 V” and low-level = “0.0 V”) are equivalent to setting an amplitude of “1.0 Vpp” and an offset of “500 mVdc”.

## To Select “DC Volts”

You can select the “DC Volts” feature from the “Utility” menu, and then set a constant dc voltage as an “Offset” value. Let's set “DC Volts” = 1.0 Vdc.

- 1 Press **Utility** and then select the **DC On** softkey.

The **Offset** value becomes selected.



- 2 Enter the desired voltage level as an “Offset”.

Enter 1.0 Vdc with the numeric keypad or knob.



You can enter any dc voltage from -5 Vdc to +5 Vdc.

## To Set the Duty Cycle of a Square Wave

At power-on, the duty cycle for square waves is 50%. You can adjust the duty cycle from 20% to 80% for output frequencies up to 5 MHz. *The following steps show you how to change the duty cycle to 30%.*

### 1 Select the square wave function.

Press the **Square** key and then set the desired output frequency to any value up to 5 MHz.

### 2 Press the “Duty Cycle” softkey.

The displayed duty cycle is either the power-on value or the percentage previously selected. The duty cycle represents the amount of time per cycle that the square wave is at a *high* level (note the icon on the right side of the display).



### 3 Enter the desired duty cycle.

Using the numeric keypad or the knob, select a duty cycle value of “30”. The function generator adjusts the duty cycle immediately and outputs a square wave with the specified value (if the output is enabled).



## To Configure a Pulse Waveform

You can configure the function generator to output a pulse waveform with variable pulse width and edge time. *The following steps show you how to configure a 500 ms pulse waveform with a pulse width of 10 ms and edge times of 50 ns.*

### 1 Select the pulse function.

Press the **Pulse** key to select the pulse function and output a pulse waveform with the default parameters.

### 2 Set the pulse period.

Press the **Period** softkey and then set the pulse period to 500 ms.



### 3 Set the pulse width.

Press the **Width** softkey and then set the pulse width to 10 ms. The pulse width represents the time from the 50% threshold of the rising edge to the 50% threshold of the next falling edge (note the display icon).



### 4 Set the edge time for both edges.

Press the **Edge Time** softkey and then set the edge time for *both* the rising and falling edges to 50 ns. The edge time represents the time from the 10% threshold to the 90% threshold of each edge (note the display icon).



## To View a Waveform Graph

In the *Graph Mode*, you can view a graphical representation of the current waveform parameters. The softkeys are listed in the same order as in the normal display mode, and they perform the same functions. However, only one label (for example, **Freq** or **Period**) is displayed for each softkey at one time.

### 1 Enable the Graph Mode.

Press the **Graph** key to enable the Graph Mode. The name of the currently selected parameter, shown in the upper-left corner of the display, and the parameter's numeric value field are both highlighted.



### 2 Select the desired parameter.

To select a specific parameter, note the softkey labels at the bottom of the display. For example, to select period, press the **Period** softkey.

- As in the normal display mode, you can edit numbers using either the numeric keypad or the knob and cursor keys.
- Parameters which normally toggle when you press a key a second time also toggle in the Graph Mode. However, you can see only one label for each softkey at one time (for example, **Freq** or **Period**).
- To exit the Graph Mode, press **Graph** again.

#### NOTE

The **Graph** key also serves as a **Local** key to restore front-panel control after remote interface operations.

## To Output a Stored Arbitrary Waveform

### NOTE

Arbitrary waveforms are optionally available with the 33210A (Option 002). To upgrade your 33210A to include arbitrary waveform functionality, go to [www.keysight.com/find/33210U](http://www.keysight.com/find/33210U).

There are five built-in arbitrary waveforms stored in non-volatile memory. *The following steps show you how to output the built-in “exponential fall” waveform from the front panel.*

### NOTE

For information on creating a custom arbitrary waveform, refer to “To Create and Store an Arbitrary Waveform” in the *User’s Guide*.

#### 1 Select the arbitrary waveform function.

When you press the **Arb** key to select the arbitrary waveform function, a temporary message is displayed indicating which waveform is currently selected (the default is “exponential rise”).

#### 2 Select the active waveform.

Press the **Select Wform** softkey and then press the **Built-In** softkey to select from the five built-in waveforms. Then press the **Exp Fall** softkey. The waveform is output using the present settings for frequency, amplitude, and offset unless you change them.



The selected waveform is now assigned to the **Arb** key. Whenever you press this key, the selected arbitrary waveform is output. To quickly determine which arbitrary waveform is currently selected, press **Arb**.

## To Use the Built-In Help System

The built-in help system is designed to provide context-sensitive assistance on any front-panel key or menu softkey. A list of help topics is also available to assist you with several front-panel operations.

### 1 View the help information for a function key.

Press and hold down the **Sine** key. If the message contains more information than will fit on the display, press the ↓ softkey or turn the knob clockwise to view the remaining information.

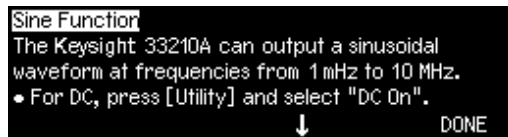

Press **DONE** to exit Help.

### 2 View the help information for a menu softkey.

Press and hold down the **Freq** softkey. If the message contains more information than will fit on the display, press the ↓ softkey or rotate the knob clockwise to view the remaining information.

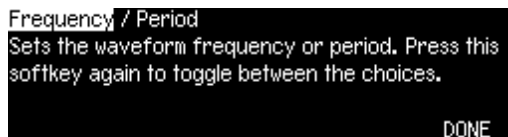

Press **DONE** to exit Help.

### 3 View the list of help topics.

Press the **Help** key to view the list of available help topics. To scroll through the list, press the  $\uparrow$  or  $\downarrow$  softkey or rotate the knob. Select the third topic “*Get HELP on any key*” and then press **SELECT**.

```
Get HELP on any key
To get context-sensitive help on any front-panel
key or menu softkey, press and hold down that key.
DONE
```

Press **DONE** to exit Help.

### 4 View the help information for displayed messages.

Whenever a limit is exceeded or any other invalid configuration is found, the function generator will display a message. For example, if you enter a value that exceeds the frequency limit for the selected function, a message will be displayed. The built-in help system provides additional information on the most recent message to be displayed.

Press the **Help** key, select the first topic “*View the last message displayed*”, and then press **SELECT**.

```
Frequency upper limit = 10.000,000MHz.
The specified value exceeds the upper limit for this
parameter. The instrument has set the parameter
equal to the upper limit.
DONE
```

Press **DONE** to exit Help.

#### NOTE

**Local Language Help:** The built-in help system is available in multiple languages. All messages, context-sensitive help, and help topics appear in the selected language. The menu softkey labels and status line messages are not translated.

To select the local language, press the **Utility** key, press the **System** softkey, and then press the **Help In** softkey. Select the desired language.



## To Rack Mount the Function Generator

You can mount the Keysight 33210A in a standard 19-inch rack cabinet using one of two optional kits available. Instructions and mounting hardware are included with each rack-mounting kit. Any Keysight *System II* instrument of the same size can be rack-mounted beside the Keysight 33210A.

### NOTE

Remove the carrying handle, and the front and rear rubber bumpers, before rack-mounting the instrument.

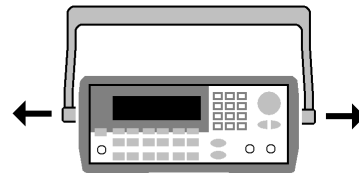
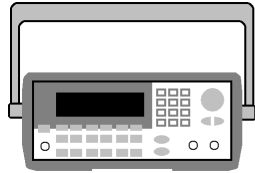

To remove the handle, rotate it to vertical and pull the ends outward.

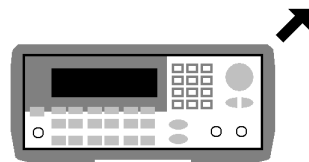

**Front**

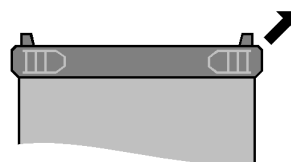

**Rear (bottom view)**

To remove the rubber bumper, stretch a corner and then slide it off.

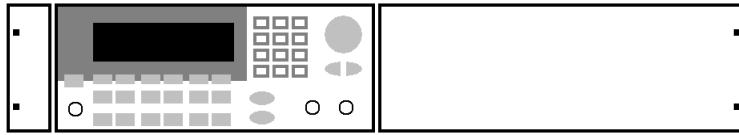

To rack mount a single instrument, order adapter kit 5063-9240.

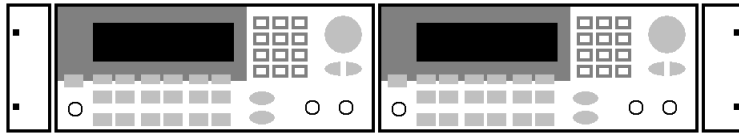

To rack mount two instruments side-by-side, order lock-link kit 5061- 8769 and flange kit 5063-9212. Be sure to use the support rails in the rack cabinet.

**NOTE**

In order to prevent overheating, do not block the flow of air into or out of the instrument. Be sure to allow enough clearance at the rear, sides, and bottom of the instrument to permit adequate internal air flow.

# 3 Front-Panel Menu Operation

Introduction	36
Front-Panel Menu Reference	37
To Select the Output Termination	41
To Reset the Function Generator	42
To Read the Calibration Information	43
To Unsecure and Secure for Calibration	44
To Store the Instrument State	47
To Configure the Remote Interface	48
To Reset the Function Generator	42

## Introduction

This chapter introduces you to the front-panel keys and menu operation. This chapter does not give a detailed description of every front-panel key or menu operation. It does, however, give you an overview of the front-panel menus and many front-panel operations. Refer to the *Keysight 33210A User's Guide* for a complete discussion of the function generator's capabilities and operation.

- [Front-Panel Menu Reference](#) on page 37
- [To Select the Output Termination](#) on page 41
- [To Reset the Function Generator](#) on page 42
- [To Read the Calibration Information](#) on page 43
- [To Unsecure and Secure for Calibration](#) on page 44
- [To Store the Instrument State](#) on page 47
- [To Configure the Remote Interface](#) on page 48

## Front-Panel Menu Reference

This section gives an overview of the front-panel menus. The remainder of this chapter contains examples of using the front-panel menus.

<b>Mod</b>	<b>Configure the modulation parameters for AM, FM, and PWM.</b>
------------	---

- |   |
|---|
| <ul style="list-style-type: none"> <li>- Select the modulation type.</li> <li>- Select an internal or external modulation source.</li> <li>- Specify AM modulation depth, modulating frequency, and modulation shape.</li> <li>- Specify FM frequency deviation, modulating frequency, and modulation shape.</li> <li>- Specify PWM deviation, modulating frequency, and modulation shape.</li> </ul> |
|---|

<b>Sweep</b>	<b>Configure the parameters for frequency sweep.</b>
--------------	--

- |  |
|--|
| <ul style="list-style-type: none"> <li>- Select linear or logarithmic sweeping.</li> <li>- Select the start/stop frequencies <u>or</u> center/span frequencies.</li> <li>- Select the time in seconds required to complete a sweep.</li> <li>- Specify a marker frequency.</li> <li>- Specify an internal or external trigger source for the sweep.</li> <li>- Specify the slope (rising or falling edge) for an external trigger source.</li> <li>- Specify the slope (rising or falling edge) of the "Trig Out" signal.</li> </ul> |
|--|

**Burst**

**Configure the parameters for burst.**

- Select the triggered (N Cycle) or externally-gated burst mode.
- Select the number of cycles per burst (1 to 50,000, or Infinite).
- Select the starting phase angle of the burst (-360° to +360°).
- Specify the time from the start of one burst to the start of the next burst.
- Specify an internal or external trigger source for the burst.
- Specify the slope (rising or falling edge) for an external trigger source.
- Specify the slope (rising or falling edge) of the “Trig Out” signal.

**Store/  
Recall**

**Store and recall instrument states.**

- Store up to four instrument states in non-volatile memory.
- Assign a custom name to each storage location.
- Recall stored instrument states.
- Restore all instrument settings to their factory default values.
- Select the instrument's power-on configuration (last or factory default).

**Utility** Configure system-related parameters.

- Generate a dc-only voltage level.
- Enable/disable the Sync signal which is output from the “Sync” connector.
- Select the output termination (1 $\Omega$  to 10 k $\Omega$ , or Infinite).
- Enable/disable amplitude autoranging.
- Select the waveform polarity (normal or inverted).
- Select the GPIB address.
- Specify the LAN configuration (IP address and network configuration).
- Select how periods and commas are used in numbers displayed on the front panel.
- Select the local language for front-panel messages and help text.
- Enable/disable the tone heard when an error is generated.
- Enable/disable the display bulb-saver mode.
- Adjust the contrast setting of the front-panel display.
- Perform an instrument self-test.
- Secure/unsecure the instrument for calibration and perform manual calibrations.
- Query the instrument’s firmware revision codes.

**Help** View the list of Help topics.

- View the last message displayed.
- View the remote command error queue.
- Get HELP on any key.
- How to generate a dc-only voltage level.
- How to generate a modulated waveform.
- How to create an arbitrary waveform.
- How to reset the instrument to its default state.
- How to view a waveform in the Graph Mode.
- How to synchronize multiple instruments.
- How to obtain Keysight Technical Support.



## To Select the Output Termination

The Keysight 33210A has a fixed series output impedance of 50 ohms to the front-panel *Output* connector. If the actual load impedance is different than the value specified, the displayed amplitude and offset levels will be incorrect. The load impedance setting is simply provided as a convenience to ensure that the displayed voltage matches the expected load.

- 1 Press **Utility**.
- 2 **Navigate the menu to set the output termination.**

Press the **Output Setup** softkey and then select the **Load** softkey.



- 3 **Select the desired output termination.**

Use the knob or numeric keypad to select the desired load impedance or press the **Load** softkey again to choose “High Z”.

## To Reset the Function Generator

To reset the instrument to its factory default state, press  and then select the **Set to Defaults** softkey. Press **YES** to confirm the operation.

*For a complete listing of the instrument's power-on and reset conditions, see "Keysight 33210A Factory Default Settings" in the User's Guide.*

## To Read the Calibration Information

You can access the instrument's calibration memory to read the calibration count and calibration message.

**Calibration Count** You can query the instrument to determine how many calibrations have been performed. Note that your instrument was calibrated before it left the factory. When you receive your instrument, read the count to determine its initial value. The count value increments by one for each calibration point, and a complete calibration may increase the value by many counts.

**Calibration Message** The instrument allows you to store one message in calibration memory. For example, you can store the date when the last calibration was performed, the date when the next calibration is due, the instrument's serial number, or even the name and phone number of the person to contact for a new calibration.

### NOTE

You can **record** a calibration message only from the remote interface and only when the instrument is unsecured.

You can **read** the message from either the front-panel or over the remote interface. You can read the calibration message whether the instrument is secured or unsecured.

### 1 Select the Cal Info interface.

Press **Utility** and then select the **Cal Info** softkey from the "Test/Cal" menu.

The first line in the display shows the calibration count.

The second line shows the calibration message.

The last line indicates the current version of the firmware.

The calibration information will time-out and disappear after a few seconds.

Select the **Cal Info** softkey to show the information again.

### 2 Exit the menu.

Press the **DONE** softkey.

## To Unsecure and Secure for Calibration

This feature allows you to enter a security code to prevent accidental or unauthorized adjustments of the instrument. When you first receive your instrument, it is secured. Before you can adjust the instrument, you must unsecure it by entering the correct security code.

- The security code is set to **AT33210A** when the instrument is shipped from the factory. The security code is stored in non-volatile memory, and does not change when power has been off, after a Factory Reset (**\*RST** command), or after an Instrument Preset (**SYSTem:PRESet** command).
- The security code may contain up to 12 alphanumeric characters. The first character must be a letter, but the remaining characters can be letters, numbers, or an underscore ( \_ ). You do not have to use all 12 characters but the first character must always be a letter.

### NOTE

If you forget your security code, you can disable the security feature by applying a temporary short inside the instrument as described in **“To Unsecure the Instrument Without the Security Code”** on page 78.

---

## To Unsecure for Calibration

### 1 Select the Secure Code interface.

Press  and then select the **Test/Cal** softkey.



### 2 Enter the Secure Code.

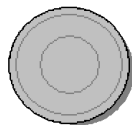

Use the knob to change the displayed character.

and



Use the arrow keys to move to the next character

When the last character of the secure code is entered, the instrument will be unsecured.

### 3 Exit the menu.

Press the **DONE** softkey.

## To Secure After Calibration

### 1 Select the Secure Code interface.

Press  and then select the **Test/Cal** softkey.



### 2 Enter a Secure Code.

Enter up to 12 alphanumeric characters. The first character must be a letter.

Use the knob to change the displayed character. Use the arrow keys to move to the next character.

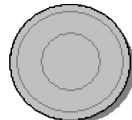

Use the knob to change the displayed character.  
and



Use the arrow keys to move to the next character

### 3 Secure the Instrument.

Select the **Secure** softkey.

### 4 Exit the menu.

Press the **DONE** softkey.

## To Store the Instrument State

You can store the instrument state in one of four non-volatile storage locations. A fifth storage location automatically holds the power-down configuration of the instrument. When power is restored, the instrument can automatically return to its state before power-down.

### 1 Select the desired storage location.

Press  and then select the **Store State** softkey.



### 2 Select a custom name for the selected location.

If desired, you can assign a custom name to each of the four locations.



- The name can contain up to 12 characters. The first character must be a letter but the remaining characters can be letters, numbers, or the underscore character (“\_”).
- To add additional characters, press the right-cursor key until the cursor is to the right of the existing name and then turn the knob.
- To delete all characters to the right of the cursor position, press .
- To use numbers in the name, you can enter them directly from the numeric keypad. Use the decimal point from the numeric keypad to add the underscore character (“\_”) to the name.

### 3 Store the instrument state.

Press the **STORE STATE** softkey. The instrument stores the selected function, frequency, amplitude, dc offset, duty cycle, symmetry, as well as any modulation parameters in use. The instrument *does not* store volatile waveforms created in the arbitrary waveform function.

## To Configure the Remote Interface

The Keysight 33210A supports remote interface communication using a choice of three interfaces: GPIB, USB, and LAN (LXI Class C compliant). All three interfaces are "live" at power up. The following sections tell how to configure the remote interface from the instrument front panel.

### NOTE

Two CDs, provided with your instrument, contain connectivity software to enable communications over the remote interfaces. See “Connectivity Software and Product CDs” in the *Keysight 33210A User’s Guide* for further information on these CDs and the software they contain.

### GPIB Configuration

#### 1 Select the “I/O” menu.

Press **Utility** and then press the **I/O** softkey.



#### 2 Set the GPIB address.

Use the knob and cursor keys or the numeric keypad to select a GPIB address in the range 0 through 30 (the factory default is “10”).

The GPIB address is shown on the front-panel display at power-on.

#### 3 Exit the menu.

Press the **DONE** softkey.

### USB Configuration

The USB interface requires no front panel configuration parameters. Just connect the Keysight 33210A to your PC with the appropriate USB cable. The interface will self configure. Press the **Show USB Id** softkey in the “I/O menu” to see the USB interface identification string. Both USB 1.1 and USB 2.0 are supported.



## LAN Configuration

There are several parameters that you may need to set to establish network communication using the LAN interface. Primarily, you will need to establish an IP address. You may need to contact your network administrator for help in establishing communication with the LAN interface.

### 1 Select the “I/O” menu.

Press **Utility** and then press the **I/O** softkey.



### 2 Select the “LAN” menu.

Press the **LAN** softkey.



You can select **Modify Settings** to change the LAN settings, or **Current Config** to view the current LAN settings (including the MAC address).

Press **Modify Settings**.



From this menu, you can select **Reset LAN** to restart the LAN, **IP Setup** to set an IP address and related parameters, **DNS Setup** to configure DNS, or **Password** to set a password for the Web Server Interface.

**NOTE**

To set a password use the knob and cursor keys (use **+/-** to delete all characters to the right of the cursor position). The Web Server Interface will prompt for the password to protect certain windows. For further information, see “Keysight 33210A Web Interface” of the User’s Guide for the Keysight 33210A.

**3 Establish an “IP Setup.”**

To use the Keysight 33210A on the network, you must first establish an IP setup, including an IP address, and possibly a subnet mask and gateway address. Press the **IP Setup** softkey. By default, both **DHCP** and **Auto IP** are set to **On**.



With **DHCP On**, an IP address will automatically be set by DHCP (Dynamic Host Configuration Protocol) when you connect the Keysight 33210A to the network, provided the DHCP server is found and is able to do so. DHCP also automatically deals with the subnet mask and gateway address, if required. *This is typically the easiest way to establish LAN communication for your instrument. All you need to do is leave **DHCP On**.*

With **Auto IP On**, if DHCP fails to assign an IP address, Auto IP will attempt to do so after a time-out period.

However, if you cannot establish communication by means of DHCP or Auto IP, you will need to manually set an IP address, and a subnet mask and gateway address if they are in use. Follow these steps:

**a Set the “IP Address.”**

Press the softkeys to select **DHCP Off** and **Auto IP Off**. The manual selection softkeys appear and the current IP address is displayed:



Contact your network administrator for the IP address to use. All IP addresses take the *dot-notation* form "nnn.nnn.nnn.nnn" where "nnn" in each case is a byte value in the range 0 through 255. You can enter a new IP address using the numeric keypad (not the knob). Just type in the numbers and the period delimiters using the keypad. Use the left cursor key as a backspace key. *Do not enter leading zeros*. For further information, see “More about IP Addresses and Dot Notation” at the end of this section.

**b Set the “Subnet Mask.”**

The subnet mask is required if your network has been divided into subnets. Ask your network administrator whether a subnet mask is needed, and for the correct mask. Press the **Subnet Mask** softkey and enter the subnet mask in the IP address format (using the keypad).



**c Set the “Default Gateway.”**

The gateway address is the address of a gateway, which is a device that connects two networks. Ask your network administrator whether a gateway is in use and for the correct address. Press the **Default Gateway** softkey and enter the gateway address in the IP address format (using the keypad).

**d Exit the “IP Setup” menu.**

Press **DONE** to return to the "Modify Settings" menu.

#### 4 Configure the “DNS Setup” (optional).

DNS (Domain Name Service) is an Internet service that translates domain names into IP addresses. Ask your network administrator whether DNS is in use, and if it is, for the host name, domain name, and DNS server address to use.

Start at the “Modify Settings” menu.



Press the **DNS Setup** softkey to display the “Host Name” field.

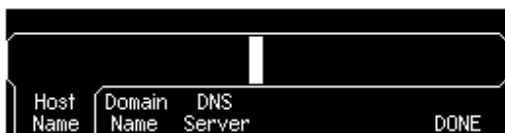

##### a Set the “Host Name.”

Enter the host name. The host name is the host portion of the domain name, which is translated into an IP address. The host name is entered as a string using the knob and cursor keys to select and change characters. The host name may include letters, numbers, and dashes (“-”). You can use the keypad for the numeric characters only.

Press **+/-** to delete all characters to the right of the cursor position.

##### b Set the “Domain Name.”

Press the **Domain Name** softkey and enter the domain name. The domain name is translated into an IP address. The domain name is entered as a string using the knob and cursor keys to select and change characters. The domain name may include letters, numbers, dashes (“-”), and periods (“.”). You can use the keypad for the numeric characters only.

Press **+/-** to delete all characters to the right of the cursor position.

##### c Set the “DNS Server” address.

Press the **DNS Server** softkey and enter the address of the DNS server in the IP address format (using the keypad).

## 5 Exit the menus.

Press **DONE** to exit each menu in turn, or press  to exit the "Utility" menu directly.

### NOTE

#### More about IP Addresses and Dot Notation

Dot-notation addresses ("nnn.nnn.nnn.nnn" where "nnn" is a byte value) such as IP addresses must be expressed with care. This is because most web software on the PC will interpret byte values with leading zeros as octal numbers. Thus, "255.255.020.011" is actually equivalent to the decimal "255.255.16.9" rather than "255.255.20.11" because ".020" is interpreted as "16" expressed in octal, and ".011" as "9". To avoid confusion it is best to use only decimal expressions of byte values (0 to 255), with no leading zeros.

The Keysight 33210A assumes that all IP addresses and other dot-notation addresses are expressed as decimal byte values, and strips all leading zeros from these byte values. Thus, if you try to enter "255.255.020.011" in the IP address field, it becomes "255.255.20.11" (a purely decimal expression). You should enter exactly the same expression, "255.255.20.11" in your PC web software to address the instrument. Do not use "255.255.020.011"—the PC will interpret that address differently due to the leading zeros.

---

THIS PAGE HAS BEEN INTENTIONALLY LEFT BLANK.

# 4 Calibration Procedures

Introduction	57
Keysight Technologies Calibration Services	58
Calibration Interval	58
Adjustment is Recommended	59
Time Required for Calibration	60
Automating Calibration Procedures	61
Recommended Test Equipment	62
Test Considerations	63
Performance Verification Tests	64
Internal Timebase Verification	68
AC Amplitude (high-impedance) Verification	69
Low Frequency Flatness Verification	71
0 dB Range Flatness Verification	72
+10 dB Range Flatness Verification	74
+20 dB Range Flatness Verification	76
Calibration Security	78
Calibration Message	80
Calibration Count	81
General Calibration/Adjustment Procedure	82
Aborting a Calibration in Progress	83
Sequence of Adjustments	84
Self-Test	85
Frequency (Internal Timebase) Adjustment	86
Internal ADC Adjustment/Self Calibration	88
Calibration Message	80
Calibration Count	81
General Calibration/Adjustment Procedure	82
Aborting a Calibration in Progress	83

## 4 Calibration Procedures

Sequence of Adjustments	84
Self-Test	85
Frequency (Internal Timebase) Adjustment	86
Internal ADC Adjustment/Self Calibration	88
Output Impedance Adjustment	90
AC Amplitude (high-impedance) Adjustment	92
Low Frequency Flatness Adjustment	94
0 dB Range Flatness Adjustments	96
+10 dB Range Flatness Adjustments	98
+20 dB Range Flatness Adjustment	100
Calibration Errors	103



## Introduction

This chapter contains procedures for verification of the instrument's performance and adjustment (calibration). The chapter is divided into the following sections:

- [Keysight Technologies Calibration Services](#) *on page 58*
- [Calibration Interval](#) *on page 58*
- [Adjustment is Recommended](#) *on page 59*
- [Time Required for Calibration](#) *on page 60*
- [Automating Calibration Procedures](#) *on page 61*
- [Recommended Test Equipment](#) *on page 62*
- [Test Considerations](#) *on page 63*
- [Performance Verification Tests](#) *on page 64*
- [Internal Timebase Verification](#) *on page 68*
- [AC Amplitude \(high-impedance\) Verification](#) *on page 69*
- [Low Frequency Flatness Verification](#) *on page 71*
- [0 dB Range Flatness Verification](#) *on page 72*
- [+10 dB Range Flatness Verification](#) *on page 74*
- [+20 dB Range Flatness Verification](#) *on page 76*
- [Calibration Security](#) *on page 78*
- [Calibration Message](#) *on page 80*
- [Calibration Count](#) *on page 81*
- [General Calibration/Adjustment Procedure](#) *on page 82*
- [Aborting a Calibration in Progress](#) *on page 83*
- [Sequence of Adjustments](#) *on page 84*
- [Self-Test](#) *on page 85*
- [Frequency \(Internal Timebase\) Adjustment](#) *on page 86*
- [Internal ADC Adjustment/Self Calibration](#) *on page 88*
- [Output Impedance Adjustment](#) *on page 90*

- [AC Amplitude \(high-impedance\) Adjustment](#) on page 92
- [Low Frequency Flatness Adjustment](#) on page 94
- [0 dB Range Flatness Adjustments](#) on page 96
- [+10 dB Range Flatness Adjustments](#) on page 98
- [+20 dB Range Flatness Adjustment](#) on page 100
- [Calibration Errors](#) on page 103

**Closed-Case Electronic Calibration** The instrument features closed-case electronic calibration. No internal mechanical adjustments are required. The instrument calculates correction factors based upon the input reference value you set. The new correction factors are stored in non-volatile memory until the next calibration adjustment is performed. Non-volatile EEPROM calibration memory does not change when power has been off or after a remote interface reset.

## Keysight Technologies Calibration Services

Keysight Technologies offers calibration services at competitive prices. When your instrument is due for calibration, contact your local Keysight Service Center for recalibration. See "[Types of Service Available](#)" on page 114 for information on contacting Keysight.

## Calibration Interval

The instrument should be calibrated on a regular interval determined by the measurement accuracy requirements of your application.

A 1-year interval is adequate for most applications. Accuracy specifications will remain valid only if adjustment is made at regular calibration intervals. Accuracy specifications are not valid beyond the 1-year calibration interval. Keysight does not recommend extending calibration intervals beyond 2 years for any application.

## Adjustment is Recommended

Specifications are valid only within the period stated from the last adjustment. Whatever calibration interval you select, Keysight recommends that complete re-adjustment always be performed at the calibration interval. This is necessary to ensure that the instrument will remain within specification for the next calibration interval. This criteria for re-adjustment provides the best long-term stability.

Performance data measured during Performance Verification Tests does not mean that the instrument will remain within these limits unless the adjustments are performed.

Use the "Calibration Count" feature (see page 81) to verify that all adjustments have been performed.

## Time Required for Calibration

The Keysight 33210A can be automatically calibrated under computer control. With computer control you can perform the complete calibration procedure and performance verification tests in approximately 30 minutes once the instrument is warmed-up (see [Test Considerations](#) on page 63). Manual adjustments and verifications, using the recommended test equipment, will take approximately 2 hours.

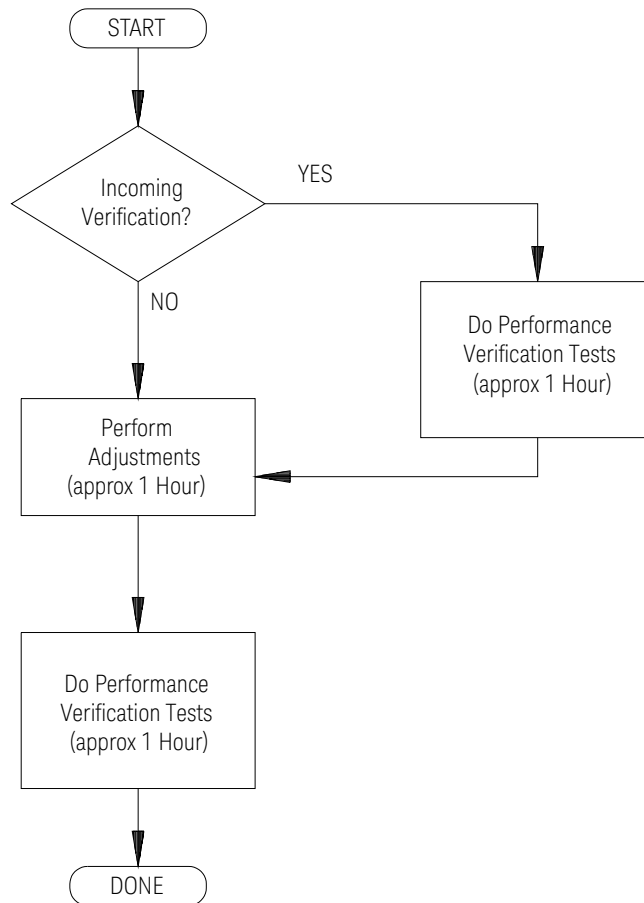

## Automating Calibration Procedures

You can automate the complete verification and adjustment procedures outlined in this chapter if you have access to programmable test equipment. You can program the instrument configurations specified for each test over the remote interface. You can then enter read-back verification data into a test program and compare the results to the appropriate test limit values.

You can also adjust the instrument from the remote interface. Remote adjustment is similar to the local front-panel procedure. You can use a computer to perform the adjustment by first selecting the required function and range. The calibration value is sent to the instrument and then the calibration is initiated over the remote interface. The instrument must be unsecured prior to initiating the calibration procedure.

For further information on programming the instrument, see Chapters 3 and 4 in the *Keysight 33210A User's Guide*.

## Recommended Test Equipment

The test equipment recommended for the performance verification and adjustment procedures is listed below. If the exact instrument is not available, substitute calibration standards of equivalent accuracy.

Instrument	Requirements	Recommended Model	Use <sup>[a]</sup>
Digital Multimeter (DMM)	ac volts, true rms, ac coupled accuracy: $\pm 0.02\%$ to 1 MHz dc volts accuracy: 50 ppm resolution: 100 $\mu\text{V}$ Resistance Offset-compensated accuracy: $\pm 0.1\Omega$	Keysight 3458A	Q, P, T
Power Meter	100 kHz to 100 MHz 1 $\mu\text{W}$ to 100 mW (-30 dBm to +20 dBm) accuracy: 0.02 dB resolution: 0.01 dB	Keysight E4418B	Q, P, T
Power Head	100 kHz to 100 MHz 1 $\mu\text{W}$ to 100 mW (-30 dBm to +20 dBm)	Keysight 8482A	Q, P, T
Attenuator	-20 dB	Keysight 8491A Opt 020	Q, P, T
Frequency Meter	accuracy: 0.1 ppm	Keysight 53131A Opt 010 (high stability)	Q, P, T
Oscilloscope <sup>[b]</sup>	500 MHz 2 Gs/second 50 $\Omega$ input termination	Keysight 54831B	T
Adapter	N type (m) to BNC (m)	N type (m) to BNC (m)	Q, P, T
Cable	BNC (m) to dual-banana (f)	Keysight 10110B	Q, P, T
Cable (2 required)	Dual banana (m) to dual banana (m)	Keysight 11000-60001	Q, P, T
Cable	RG58, BNC (m) to dual banana	Keysight 11001-60001	Q, P, T
Cable	RG58, BNC (m) to BNC (m)	Keysight 8120-1840	Q, P, T

[a] Q = Quick Verification P = Performance Verification T = Troubleshooting

[b] An oscilloscope is not required for calibration, only for troubleshooting.

## Test Considerations

For optimum performance, all procedures should comply with the following recommendations:

- Assure that the calibration ambient temperature is stable and between 21 °C and 25 °C (23 °C  $\pm$ 2 °C).
- Assure ambient relative humidity is less than 80%.
- Allow a 1-hour warm-up period before verification or adjustment.
- Keep the measurement cables as short as possible, consistent with the impedance requirements.
- Use only RG-58 or equivalent 50 $\Omega$  cable.

## Performance Verification Tests

Use the Performance Verification Tests to verify the measurement performance of the instrument. The performance verification tests use the instrument's specifications listed in the **"Specifications"** chapter beginning on page 15.

You can perform three different levels of performance verification tests:

- **Self-Test** A series of internal verification tests that give high confidence that the instrument is operational.
- **Quick Verification** A combination of the internal self-tests and selected verification tests.
- **Performance Verification Tests** An extensive set of tests that are recommended as an acceptance test when you first receive the instrument or after performing adjustments.

### Self-Test

A brief power-on self-test occurs automatically whenever you turn on the instrument. This limited test assures that the instrument is operational.

To perform a complete self-test:

- 1 Press **Utility** on the front panel.
- 2 Select the **Self Test** softkey from the "Test/Cal" menu.

A complete description of the self-tests can be found in **Chapter 6**. The instrument will automatically perform the complete self-test procedure when you release the key. The self-test will complete in approximately 15 seconds.

- If the self-test is successful, "Self Test Passed" is displayed on the front panel.
- If the self-test fails, "Self Test Failed" and an error number are displayed.
- If repair is required, see **Chapter 6, "Disassembly and Repair"**, for further details.



## Quick Performance Check

The quick performance check is a combination of internal self-test and an abbreviated performance test (specified by the letter **Q** in the performance verification tests). This test provides a simple method to achieve high confidence in the instrument's ability to functionally operate and meet specifications. These tests represent the absolute minimum set of performance checks recommended following any service activity. Auditing the instrument's performance for the quick check points (designated by a **Q**) verifies performance for normal accuracy drift mechanisms. This test does not check for abnormal component failures.

To perform the quick performance check, do the following:

- 1 Perform a complete self-test. A procedure is given on page 64.
- 2 Perform only the performance verification tests indicated with the letter **Q**.
- 3 If the instrument fails the quick performance check, adjustment or repair is required.

## Performance Verification Tests

The performance verification tests are recommended as acceptance tests when you first receive the instrument. The acceptance test results should be compared against the specifications given in [Chapter 1](#). After acceptance, you should repeat the performance verification tests at every calibration interval.

If the instrument fails performance verification, adjustment or repair is required.

Adjustment is recommended at every calibration interval. If adjustment is not made, you must guard band, using no more than 80% of the specifications listed in [Chapter 1](#), as the verification limits.

### **Special Note:** **Amplitude and Flatness Verification Procedures**

Measurements made during the "[AC Amplitude \(high-impedance\) Verification](#)" procedure (see page 69) are used as reference measurements in the flatness verification procedures (beginning on page 71). Additional reference measurements and calculated references are used in the flatness verification procedures. Photo-copy and use the table on page 67 to record these reference measurements and perform the calculations.

The flatness verification procedures use both a DMM and a Power Meter to make the measurements. To correct the difference between the DMM and Power Meter measurements, the Power Meter reference measurement level is adjusted to set the 0.00 dB level to the DMM measurement made at 1 kHz. The flatness error of the DMM at 100 KHz is used to set the required 0.00 dB reference.

The instrument internally corrects the difference between the high-Z input of the DMM and the 50  $\Omega$  input of the Power Meter when setting the output level.

The reference measurements must also be converted from  $V_{rms}$  (made by the DMM) to dBm (made by the Power Meter).

The equation used for the conversion from  $V_{rms}$  (High-Z) to dBm (at 50  $\Omega$ ) is as follows:

$$\text{Power (dBm)} = 10 \log(5.0 * V_{rms}^2)$$

Flatness measurements for the -10 dB, -20 dB, and -30 dB attenuator ranges are verified as a part of the 0 dB verification procedure. No separate verification procedure is given for these ranges.

## Amplitude and Flatness Verification Worksheet

### 1 Enter the following measurements (from procedure on page 69).

$$1\text{kHz\_0dB\_reference} = \underline{\hspace{2cm}} \text{ Vrms}$$

$$1\text{kHz\_10dB\_reference} = \underline{\hspace{2cm}} \text{ Vrms}$$

$$1\text{kHz\_20dB\_reference} = \underline{\hspace{2cm}} \text{ Vrms}$$

### 2 Calculate the dBm value of the rms voltages.

$$\begin{aligned} 1\text{kHz\_0dB\_reference\_dBm} &= 10 * \log(5.0 * 1\text{kHz\_0dB\_reference}^2) \\ &= \underline{\hspace{2cm}} \text{ dBm} \end{aligned}$$

$$\begin{aligned} 1\text{kHz\_10dB\_reference\_dBm} &= 10 * \log(5.0 * 1\text{kHz\_10dB\_reference}^2) \\ &= \underline{\hspace{2cm}} \text{ dBm} \end{aligned}$$

$$\begin{aligned} 1\text{kHz\_20dB\_reference\_dBm} &= 10 * \log(5.0 * 1\text{kHz\_20dB\_reference}^2) \\ &= \underline{\hspace{2cm}} \text{ dBm} \end{aligned}$$

### 3 Enter the following measurements (from the procedure on page 71).

$$100\text{kHz\_0dB\_reference} = \underline{\hspace{2cm}} \text{ Vrms}$$

$$100\text{kHz\_10dB\_reference} = \underline{\hspace{2cm}} \text{ Vrms}$$

$$100\text{kHz\_20dB\_reference} = \underline{\hspace{2cm}} \text{ Vrms}$$

### 4 Calculate the dBm value of the rms voltages.

$$\begin{aligned} 100\text{kHz\_0dB\_reference\_dBm} &= 10 * \log(5.0 * 100\text{kHz\_0dB\_reference}^2) \\ &= \underline{\hspace{2cm}} \text{ dBm} \end{aligned}$$

$$\begin{aligned} 100\text{kHz\_10dB\_reference\_dBm} &= 10 * \log(5.0 * 100\text{kHz\_10dB\_reference}^2) \\ &= \underline{\hspace{2cm}} \text{ dBm} \end{aligned}$$

$$\begin{aligned} 100\text{kHz\_20dB\_reference\_dBm} &= 10 * \log(5.0 * 100\text{kHz\_20dB\_reference}^2) \\ &= \underline{\hspace{2cm}} \text{ dBm} \end{aligned}$$

### 5 Calculate the offset values.

$$\begin{aligned} 100\text{kHz\_0dB\_offset} &= 100\text{kHz\_0dB\_reference\_dBm} - 1\text{kHz\_0dB\_reference\_dBm} \\ &= \underline{\hspace{2cm}} \text{ dBm (use on page 72)} \end{aligned}$$

$$\begin{aligned} 100\text{kHz\_10dB\_offset} &= 100\text{kHz\_10dB\_reference\_dBm} - 1\text{kHz\_10dB\_reference\_dBm} \\ &= \underline{\hspace{2cm}} \text{ dBm (use on page 74)} \end{aligned}$$

$$\begin{aligned} 100\text{kHz\_20dB\_offset} &= 100\text{kHz\_20dB\_reference\_dBm} - 1\text{kHz\_20dB\_reference\_dBm} \\ &= \underline{\hspace{2cm}} \text{ dBm (use on page 76)} \end{aligned}$$

## Internal Timebase Verification

This test verifies the output frequency accuracy of the instrument. All output frequencies are derived from a single generated frequency.

- 1 Connect a frequency counter as shown below (the frequency counter input should be terminated at 50  $\Omega$ ).

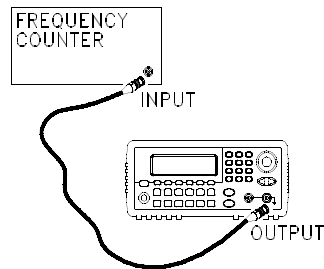

- 2 Set the instrument to the output described in the table below and measure the output frequency. *Be sure the instrument output is enabled.*

Keysight 33210A			Measurement	
Function	Amplitude	Frequency	Nominal	Error
Q Sine Wave	1.00 Vpp	10.000,000,0 MHz	10.000 MHz	$\pm 200$ Hz <sup>[a]</sup>

[a] The error is  $\pm 100$  Hz within 90 days of calibration, or  $\pm 200$  Hz within one year.

- 3 Compare the measured frequency to the test limits shown in the table.

## AC Amplitude (high-impedance) Verification

This procedure checks the ac amplitude output accuracy at a frequency of 1 kHz, and establishes reference measurements for the higher frequency flatness verification procedures.

- 1 Set the DMM to measure Vrms Volts. Connect the DMM as shown below.

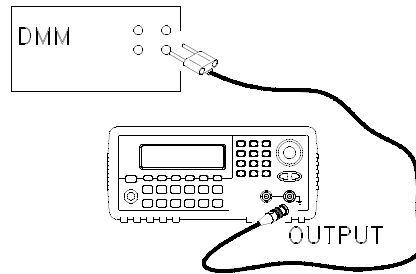

- 2 Set the instrument to each output described in the table below and measure the output voltage with the DMM. Press **Utility** to set the output impedance to High-Z. Be sure the output is enabled.

Keysight 33210A				Measurement	
Output Setup	Function	Frequency	Amplitude	Nominal	Error <sup>[a]</sup>
Q	High Z	Sine Wave	1.000 kHz	20.0 mVrms	0.020 Vrms ± <b>0.00091 Vrms</b>
Q	High Z	Sine Wave	1.000 kHz	67.0 mVrms	0.067 Vrms ± <b>0.00138 Vrms</b>
Q	High Z	Sine Wave	1.000 kHz	200.0 mVrms	0.200 Vrms ± <b>0.00271 Vrms</b>
Q	High Z	Sine Wave	1.0v00 kHz	670.0 mVrms	0.670 Vrms <sup>[b]</sup> ± <b>0.00741 Vrms</b>
Q	High Z	Sine Wave	1.000 kHz	2.000 Vrms	2.0000 Vrms <sup>[c]</sup> ± <b>0.0207 Vrms</b>
Q	High Z	Sine Wave	1.000 kHz	7.000 Vrms	7.000 Vrms <sup>[d]</sup> ± <b>0.0707 Vrms</b>
Q	High Z	Square Wave <sup>[a]</sup>	1.000 kHz	900.0 mVrms	0.900 Vrms ± <b>0.0100 Vrms</b>

[a] Based upon 1% of setting ±1 mVpp (50 W); converted to Vrms for High-Z.

[b] Enter the measured value on the worksheet (76) as *1kHz\_0dB\_reference*.

[c] Enter the measured value on the worksheet (76) as *1kHz\_10dB\_reference*.

## 4 Calibration Procedures

[d] Enter the measured value on the worksheet (76) as *1kHz\_20dB\_reference*.

**3** Compare the measured voltage to the test limits shown in the table.

## Low Frequency Flatness Verification

This procedure checks the AC amplitude flatness at 100 kHz using the reference measurements recorded in the "[Amplitude and Flatness Verification Worksheet](#)". These measurements also establish an error value used to set the power meter reference. The transfer measurements are made at a frequency of 100 kHz using both the DMM and the power meter.

- 1 Set the DMM to measure ac Volts. Connect the DMM as shown in the figure on page 69.
- 2 Set the instrument to each output described in the table below and measure the output voltage with the DMM. Press **Utility** to set the output impedance to High-Z. Be sure the output is enabled.

Keysight 33210A				Measurement		
Output Setup	Function	Frequency	Amplitude	Nominal	Error	
Q	High Z	Sine Wave	100.000 kHz	670.0 mVrms	0.670 Vrms <sup>[a]</sup>	± 0.0067 Vrms
Q	High Z	Sine Wave	100.000 kHz	2.000 Vrms	2.000 Vrms <sup>[b]</sup>	± 0.020 Vrms
Q	High Z	Sine Wave	100.000 kHz	7.000 Vrms	7.000 Vrms <sup>[c]</sup>	± 0.070 Vrms

[a] Enter the measured value on the worksheet (page 67) as *100kHz\_0dB\_reference*.

[b] Enter the measured value on the worksheet (page 67) as *1k00Hz\_10dB\_reference*.

[c] Enter the measured value on the worksheet (page 67) as *100kHz\_20dB\_reference*.

- 3 Compare the measured voltage to the test limits shown in the table.
- 4 You have now recorded all the required measurements on the worksheet (page 67). Complete the worksheet by making all the indicated calculations.

## 0 dB Range Flatness Verification

This procedure checks the high frequency ac amplitude flatness above 100 kHz on the 0dB attenuator range. (Flatness is relative to 1 kHz.)

- 1 Connect the power meter to measure the output amplitude of the instrument as shown below.

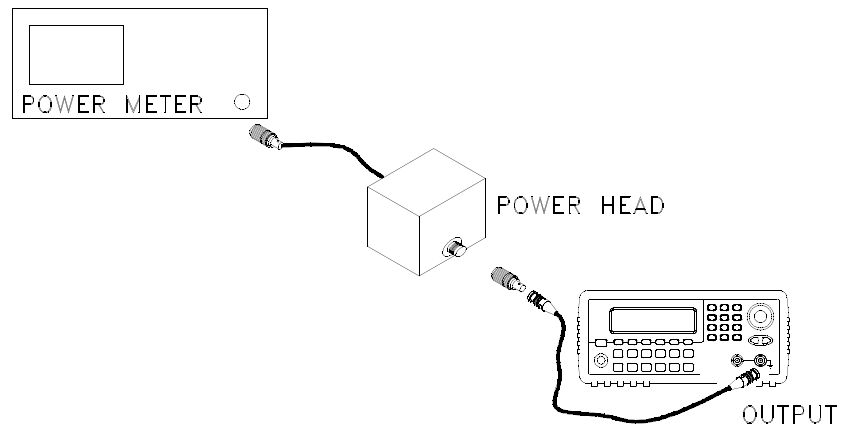

- 2 Set up the function generator as follows:
  - Output impedance: 50  $\Omega$  (press **Utility** and select Output Setup).
  - Waveform: Sine
  - Frequency: 100 kHz
  - Amplitude: 3.51 dBm

*Make sure the output is enabled.*
- 3 On the power meter, use the *Relative Power* function to set the current reading as the reference value. This will allow you to compare future measurement results in dB.
- 4 Set the power meter *offset* to equal the *100kHz\_0dB\_offset* value previously calculated. This sets the power meter to directly read the flatness error specification relative to 1 kHz. *100kHz\_0dB\_offset* is calculated on the "[Amplitude and Flatness Verification Worksheet](#)".



- 5 Set the function generator to each output described in the table below and measure the output amplitude with the power meter (the relative measurement in dB).

Keysight 33210A				Measurement		
Output Setup	Function	Amplitude	Frequency	Nominal	Error	
Q	50 $\Omega$	Sine Wave	+3.51 dBm	100.000 kHz	0 dB	$\pm 0.1$ dB
	50 $\Omega$	Sine Wave	+3.51 dBm	200.000 kHz	0 dB	$\pm 0.2$ dB
	50 $\Omega$	Sine Wave	+3.51 dBm	500.000 kHz	0 dB	$\pm 0.2$ dB
	50 $\Omega$	Sine Wave	+3.51 dBm	2.000 MHz	0 dB	$\pm 0.2$ dB
	50 $\Omega$	Sine Wave	+3.51 dBm	3.000 MHz	0 dB	$\pm 0.2$ dB
Q	50 $\Omega$	Sine Wave	+3.51 dBm	4.000 MHz	0 dB	$\pm 0.2$ dB
	50 $\Omega$	Sine Wave	+3.51 dBm	5.000 MHz	0 dB	$\pm 0.2$ dB
	50 $\Omega$	Sine Wave	+3.51 dBm	8.000 MHz	0 dB	$\pm 0.3$ dB
Q	50 $\Omega$	Sine Wave	+3.51 dBm	10.000 MHz	0 dB	$\pm 0.3$ dB

- 6 Compare the measured output to the test limits shown in the table.

## +10 dB Range Flatness Verification

This procedure checks the high frequency ac amplitude flatness above 100 kHz on the +10dB attenuator range. (Flatness is relative to 1 kHz.)

- 1 Connect the power meter to measure the output amplitude of the instrument as shown on page 72.
- 2 Set up the function generator as follows:
  - Output impedance: 50  $\Omega$  (press Utility and select Output Setup).
  - Waveform: Sine
  - Frequency: 100 kHz
  - Amplitude: 13.00 dBm

*Make sure the output is enabled.*
- 3 On the power meter, use the *Relative Power* function to set the current reading as the reference value. This will allow you to compare future measurement results in dB.
- 4 Set the power meter *offset* to equal the *100kHz\_10dB\_offset* value previously calculated. This sets the power meter to directly read the flatness error specification relative to 1 kHz. *100kHz\_10dB\_offset* is calculated on the "[Amplitude and Flatness Verification Worksheet](#)".
- 5 Set the instrument to each output described in the table below and measure the output amplitude with the power meter (the relative measurement in dB).

Keysight 33210A					Measurement	
	Output Setup	Function	Amplitude	Frequency	Nominal	Error
Q	50 $\Omega$	Sine Wave	+13.00 dBm	100.000 kHz	0 dB	<b><math>\pm 0.1</math> dB</b>
	50 $\Omega$	Sine Wave	+13.00 dBm	200.000 kHz	0 dB	<b><math>\pm 0.2</math> dB</b>
	50 $\Omega$	Sine Wave	+13.00 dBm	500.000 kHz	0 dB	<b><math>\pm 0.2</math> dB</b>
	50 $\Omega$	Sine Wave	+13.00 dBm	2.000 MHz	0 dB	<b><math>\pm 0.2</math> dB</b>
	50 $\Omega$	Sine Wave	+13.00 dBm	3.000 MHz	0 dB	<b><math>\pm 0.2</math> dB</b>
Q	50 $\Omega$	Sine Wave	+13.00 dBm	4.000 MHz	0 dB	<b><math>\pm 0.2</math> dB</b>
	50 $\Omega$	Sine Wave	+13.00 dBm	5.000 MHz	0 dB	<b><math>\pm 0.2</math> dB</b>

Keysight 33210A				Measurement	
Output Setup	Function	Amplitude	Frequency	Nominal	Error
50 $\Omega$	Sine Wave	+13.00 dBm	8.000 MHz	0 dB	<b><math>\pm 0.3</math> dB</b>
50 $\Omega$	Sine Wave	+13.00 dBm	10.000 MHz	0 dB	<b><math>\pm 0.3</math> dB</b>

Q

6 Compare the measured output to the test limits shown in the table.

## +20 dB Range Flatness Verification

This procedure checks the high frequency ac amplitude flatness above 100 kHz on the +20dB attenuator range. (Flatness is relative to 1 kHz.)

- 1 Connect the power meter to measure the output voltage of the instrument as shown below.

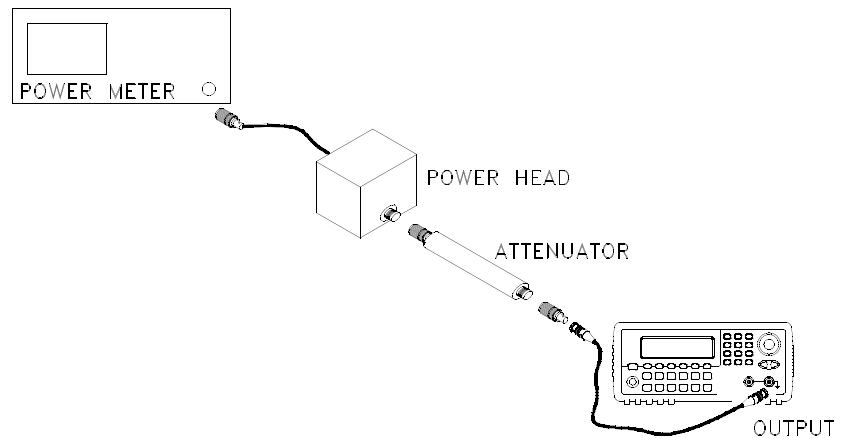

### CAUTION

Most power meters will require an attenuator or special power head to measure the +20 dB output.

- 2 Set up the function generator as follows:
  - Output impedance: 50  $\Omega$  (press **Utility** and select Output Setup).
  - Waveform: Sine
  - Frequency: 100 kHz
  - Amplitude: 23.90 dBm

*Make sure the output is enabled.*

- 3 On the power meter, use the *Relative Power* function to set the current reading as the reference value. This will allow you to compare future measurement results in dB.
- 4 Set the power meter *offset* to equal the *100kHz\_20dB\_offset* value previously calculated. This sets the power meter to directly read the flatness error specification relative to 1 kHz. *100kHz\_20dB\_offset* is calculated on the "[Amplitude and Flatness Verification Worksheet](#)".
- 5 Set the instrument to each output described in the table below and measure the output amplitude with the power meter.

Keysight 33210A				Measurement		
Output Setup	Function	Amplitude	Frequency	Nominal	Error	
Q	50 Ω	Sine Wave	+23.90 dBm	100.000 kHz	0 dB	± 0.1 dB
	50 Ω	Sine Wave	+23.90 dBm	200.000 kHz	0 dB	± 0.2 dB
	50 Ω	Sine Wave	+23.90 dBm	500.000 kHz	0 dB	± 0.2 dB
	50 Ω	Sine Wave	+23.90 dBm	2.000 MHz	0 dB	± 0.2 dB
	50 Ω	Sine Wave	+23.90 dBm	3.000 MHz	0 dB	± 0.2 dB
Q	50 Ω	Sine Wave	+23.90 dBm	4.000 MHz	0 dB	± 0.2 dB
	50 Ω	Sine Wave	+23.90 dBm	5.000 MHz	0 dB	± 0.2 dB
	50 Ω	Sine Wave	+23.90 dBm	8.000 MHz	0 dB	± 0.3 dB
Q	50 Ω	Sine Wave	+23.90 dBm	10.000 MHz	0 dB	± 0.3 dB

- 6 Compare the measured output to the test limits shown in the table.

## Calibration Security

This feature allows you to enter a security code to prevent accidental or unauthorized adjustments of the instrument. When you first receive your instrument, it is secured. Before you can adjust the instrument, you must unsecure it by entering the correct security code.

See *“To Unsecure and Secure for Calibration”* on page 44 for a procedure to enter the security code from the front panel. Use the **CAL:SEC:STAT ON** command to enter the security code using the remote interface.

- The security code is set to **AT33210A** when the instrument is shipped from the factory. The security code is stored in non-volatile memory, and does not change when power has been off, after a Factory Reset (\*RST command), or after an Instrument Preset (SYSTem:PRESet command).
- The security code may contain up to 12 alphanumeric characters. The first character must be a letter, but the remaining characters can be letters, numbers, or an underscore ( \_ ). You do not have to use all 12 characters but the first character must always be a letter.

**NOTE**

If you forget your security code, you can disable the security feature by applying a temporary short inside the instrument as described below.

---

### To Unsecure the Instrument Without the Security Code

To unsecure the instrument without the correct security code, follow the steps below. See *“To Unsecure and Secure for Calibration”* on page 44. See *“Electrostatic Discharge (ESD) Precautions”* on page 116 before beginning this procedure.

**NOTE**

If you do not have a record of the security code, there are two codes you may wish to try before you use the procedure below. First try **AT33210A** (the factory default code). If that code does not work, you may wish to try the single letter **A** as the security code. If someone has re-secured calibration without entering a new code, the default code is the letter **A**.

---

- 1 Disconnect the power cord and all input connections.

- 2 Disassemble the instrument using the “[General Disassembly Procedure](#)” on page 123.
- 3 Apply a temporary short between the two exposed metal pads on the A1 assembly. The general location is shown in the figure below. On the PC board, the pads are marked **CAL ENABLE**.

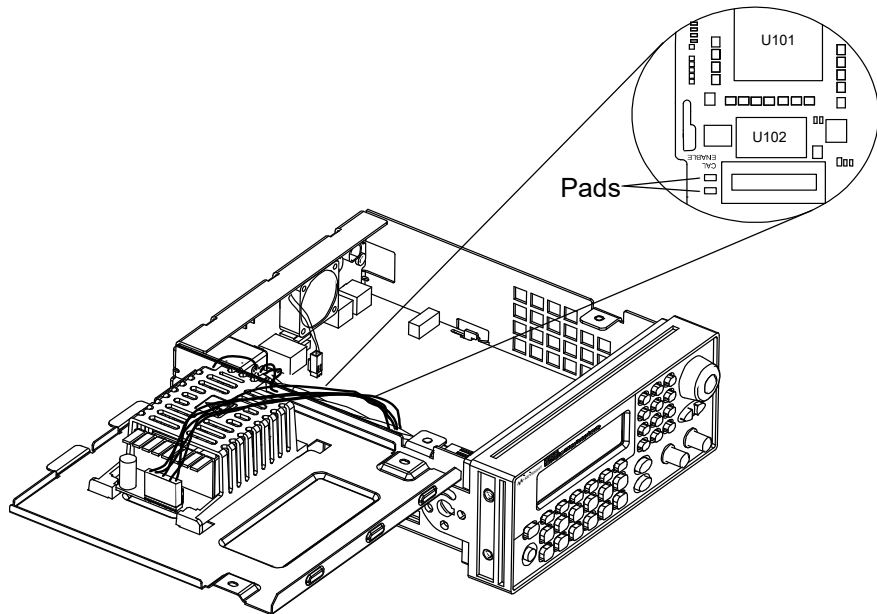

- 4 Apply power and turn on the instrument.

**WARNING**

Be careful not to touch the power line connections or high voltages on the power supply module. Power is present even if the instrument is turned off.

- 5 The display will show the message “Calibration security has been disabled”. The instrument is now unsecured.
- 6 Turn off the instrument and remove the power cord.
- 7 Reassemble the instrument.

Now you can enter a new security code, see “[To Unsecure and Secure for Calibration](#)” on page 44. Be sure you record the new security code.

## Calibration Message

The instrument allows you to store one message in calibration memory. For example, you can store the date when the last calibration was performed, the date when the next calibration is due, the instrument's serial number, or even the name and phone number of the person to contact for a new calibration.

You can **record** a calibration message only from the remote interface and only when the instrument is unsecured. Use the **CAL:STRING <message>** command.

You can **read** the message from either the front-panel or over the remote interface. You can read the calibration message whether the instrument is secured or unsecured. Reading the calibration message from the front panel is described on [“To Read the Calibration Information”](#) on page 43. Use the **CAL:STRING?** query to read the message over the remote interface.



## Calibration Count

You can query the instrument to determine how many calibrations have been performed. Note that your instrument was calibrated before it left the factory. When you receive your instrument, read the count to determine its initial value. The count value increments by one for each calibration point, and a complete calibration may increase the value by many counts. See [“To Read the Calibration Information”](#) on page 43. Use the `CAL:COUNT?` query to read the count over the remote interface.

## General Calibration/Adjustment Procedure

The following procedure is the recommended method to complete an instrument calibration. This procedure is an overview of the steps required for a complete calibration. Additional details for each step in this procedure are given in the appropriate sections of this chapter.

- 1 Read "**Test Considerations**" on page 63.
- 2 Unsecure the instrument for calibration (see page 78).
- 3 Perform the verification tests, beginning on page 64, to characterize the instrument (incoming data).
- 4 Press **Utility** on the front panel.
- 5 Select the "Test / Cal" menu.
- 6 Select **Perform Cal.**
- 7 Enter the **Setup Number** for the procedure being performed. The default setup number is "1" and, from the front panel, the number will increment as the procedures are performed.
- 8 Select **BEGIN**.
- 9 For setups that require an input, adjust the value shown in the display to the measured value and select **ENTER VALUE**.
- 10 The setup will automatically advance to the next required value.

**NOTE**

To cancel the adjustment procedure, select **CANCEL STEP**. The display will return to the setup number entry.

---

- 11 When finished, select **END CAL**.
- 12 Secure the instrument against calibration.
- 13 Note the new security code and calibration count in the instrument's maintenance records.

## Aborting a Calibration in Progress

Sometimes it may be necessary to abort a calibration after the procedure has already been initiated. You can abort a calibration at any time by turning off the power. When performing a calibration from the remote interface, you can abort a calibration by issuing a remote interface device clear message followed by a \*RST.

The instrument stores calibration constants at the end of each adjustment procedure. If you lose power, or otherwise abort an adjustment in progress, you will only need to perform the interrupted adjustment procedure again.

### CAUTION

If power is lost when the instrument is attempting to write new calibration constants to EEPROM, you may lose all calibration constants for the function. Typically, upon re-applying power, the instrument will report error “-313, Calibration Memory Lost”.

---

## Sequence of Adjustments

The adjustment sequence shown in the following sections of this chapter is recommended to minimize the number of test equipment set-up and connection changes.

You may perform individual adjustments as necessary. Setups 1 through 7 **must** be performed in order and **must** be performed **before** any other setup procedure.

## Self-Test

Self-Test is performed as the first step to ensure the instrument is in working order before beginning any additional adjustments.

### NOTE

Be sure to follow the requirements listed in **“Test Considerations”** on page 63 before beginning any adjustments.

- 1 Press **Utility** on the front panel. Select **Perform Cal** on the “Test / Cal” menu. Enter setup number “1” and select **BEGIN**.

#### Setup

1	Performs the Self-test. The Main Output is disabled during test.
---	--

- 2 If the instrument fails any self-test, you must repair the instrument before continuing the adjustment procedures.

### NOTE

The self-test procedure takes approximately 15 seconds to complete.

## Frequency (Internal Timebase) Adjustment

The function generator stores a calibration constant that sets the VCXO to output exactly 10 MHz.

- 1 Set the frequency counter resolution to better than 0.1 ppm and the input termination to 50  $\Omega$  (if your frequency counter does not have a 50  $\Omega$  input termination, you must provide an external termination). Make the connections shown below.

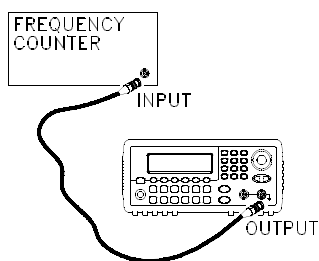

- 2 Use a frequency counter to measure the output frequency for each setup in the following table.

Setup	Nominal Signal		
	Frequency	Amplitude	
2	<10 MHz	1 Vpp	Output frequency is slightly less than 10MHz
3	>10 MHz	1 Vpp	Output frequency is slightly more than 10MHz
4	~10 MHz	1 Vpp	Output frequency should be near 10MHz
5 <sup>[a]</sup>	10 MHz	1 Vpp	Output frequency should be 10MHz $\pm$ 1 ppm

[a] Constants are stored after completing this setup.

- 3 Using the numerical keypad or knob, adjust the displayed frequency at each setup to match the measured frequency. Select **ENTER VALUE**.
- 4 After performing setup 5:

- a** If your calibration procedures require you to verify the adjustment just made, exit the calibration menu and perform “**Internal Timebase Verification**” on page 68.
- b** If you are making all the adjustments and then verifying the instrument’s performance, continue with the next procedure in this chapter.

## Internal ADC Adjustment/Self Calibration

The function generator stores calibration constants related to the gain and offset of the internal ADC. Setup 6 **must** always be performed **before** any later adjustments are attempted. The internal ADC is then used as a source for the calibration constants generated in setup 7.

- 1 Make the connections as shown below.

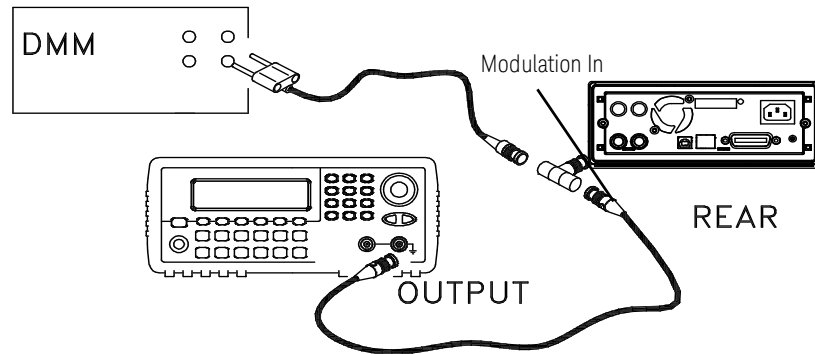

- 2 Set the DMM to display 5 1/2 digits.
- 3 Enter the following setup, and then measure the dc value.

Nominal Signal		
Setup	DC level	
6 <sup>[a]</sup>	~1.1 Vdc ±10%	Calibrates the internal ADC.

[a] Constants are stored after completing this setup.

- 4 Enter the measured value of the dc source using the numeric keypad or knob.

### NOTE

This setup requires approximately 15 seconds to complete.

- 5 Disconnect all cables from the rear panel Modulation In connector.



- 6** Enter and begin the following setup.

Setup	
7 <sup>[a]</sup>	Self-calibration. The output is disabled.

---

[a] Constants are stored after completing this setup.

- 7** There are no specific operational verification tests for setups 6 and 7 since the constants generated affect almost all behavior of the instrument. Continue with the next adjustment procedure in this chapter.

## Output Impedance Adjustment

The function generator stores calibration constants for the output impedance. The output impedance constants are generated with and without the distortion filter and using all five attenuator paths.

- 1 Set the DMM to measure offset-compensated, four-wire Ohms. Set the DMM to use 100 NPLC integration. Make the connections as shown below.

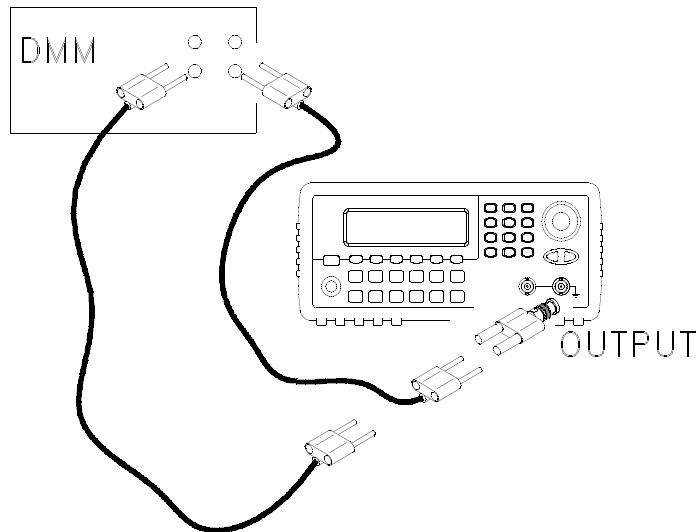

- 2 Use the DMM to make a resistance measurement at the front panel Output connector for each setup in the following table. The expected measured value is approximately 50  $\Omega$ .

Setup	
g <sup>[a]</sup>	-30dB range
g <sup>[a]</sup>	-20dB range
10 <sup>[a]</sup>	-10dB range

Setup	
11 <sup>[a]</sup>	0dB range
12 <sup>[a]</sup>	+10dB range

[a] Constants are stored after completing this setup.

- 3 Using the numeric keypad or knob, adjust the displayed impedance at each setup to match the measured impedance. Select **ENTER VALUE**.
- 4 There are no specific operational verification tests for Output Impedance. Continue with the next adjustment procedure in this chapter.

## AC Amplitude (high-impedance) Adjustment

The function generator stores a calibration constant for each high-impedance attenuator path. The gain coefficient of each path is calculated using two measurements; one with the waveform DAC at + output and one with waveform DAC at – output. The setups, therefore, must be performed in pairs.

- 1 Connect the DMM as shown below.

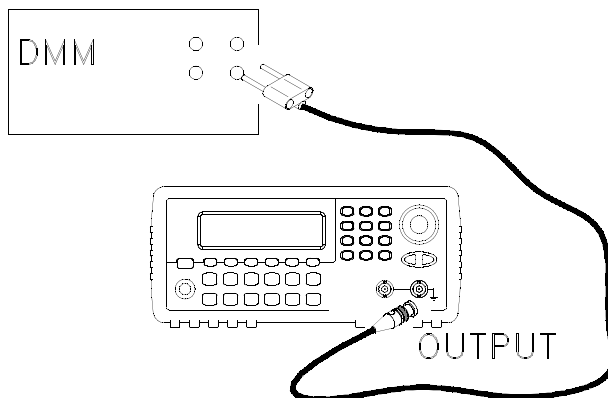

- 2 Use the DMM to measure the dc voltage at the front-panel Output connector for each setup in the following table.

Setup	Nominal Signal	
	DC level	
13	+0.015 V	Output of -30dB range
14 <sup>[a]</sup>	-0.015 V	Output of -30dB range
15	+0.05 V	Output of -20dB range
16 <sup>[a]</sup>	-0.05 V	Output of -20dB range
17	+0.15 V	Output of -10dB range
18 <sup>[a]</sup>	-0.15 V	Output of -10dB range
19	+0.50 V	Output of 0dB range

Setup	Nominal Signal	
	DC level	
20 <sup>[a]</sup>	-0.50 V	Output of 0dB range
21	+0.15 V	Output of -10dB range (Amplifier In)
22 <sup>[a]</sup>	-0.15 V	Output of -10dB range (Amplifier In)
23	+0.50 V	Output of 0dB range (Amplifier In)
24 <sup>[a]</sup>	-0.50 V	Output of 0dB range (Amplifier In)
25	+1.5 V	Output of +10dB range (Amplifier In)
26 <sup>[a]</sup>	-1.5 V	Output of +10dB range (Amplifier In)
27	+5 V	Output of +20dB range (Amplifier In)
28 <sup>[a]</sup>	-5 V	Output of +20dB range (Amplifier In)

[a] Constants are stored after completing this setup.

- 3 Using the numeric keypad or knob, adjust the displayed voltage at each setup to match the measured voltage. Select **ENTER VALUE**. (Entered values are rounded to the nearest 100  $\mu$ V).
- 4 After performing setup 28:
  - a If your calibration procedures require you to verify the adjustment just made, exit the calibration menu and perform “AC Amplitude (high-impedance) Verification” on page 69.
  - b If you are making all the adjustments and then verifying the instrument's performance, continue with the next procedure in this chapter.

## Low Frequency Flatness Adjustment

The Low Frequency Flatness adjustment calculates the flatness response of 3 attenuator paths with the Elliptical filter and 2 attenuator paths with the Linear Phase filter.

- 1 Set the DMM to measure  $V_{rms}$ . Make the connections shown on page 92.
- 2 Use the DMM to measure the output voltage for each of the setups in the table below.

Setup	Nominal Signal		
	Frequency	Amplitude	
29 <sup>[a]</sup>	1 kHz	0.56 $V_{rms}$	Flatness for 0dB, Elliptical Filter
30 <sup>[a]</sup>	100 kHz	0.56 $V_{rms}$	Flatness for 0dB, Elliptical Filter
31 <sup>[a]</sup>	1 kHz	0.56 $V_{rms}$	Flatness for 0dB, Linear Phase Filter
32 <sup>[a]</sup>	100 kHz	0.56 $V_{rms}$	Flatness for 0dB, Linear Phase Filter
33 <sup>[a]</sup>	1 kHz	1.7 $V_{rms}$	Flatness for +10dB, Elliptical Filter
34 <sup>[a]</sup>	100 kHz	1.7 $V_{rms}$	Flatness for +10dB, Elliptical Filter
35 <sup>[a]</sup>	1 kHz	5.6 $V_{rms}$	Flatness for +20dB, Elliptical Filter
36 <sup>[a]</sup>	100 kHz	5.6 $V_{rms}$	Flatness for +20dB, Elliptical Filter
37 <sup>[a]</sup>	1 kHz	5.6 $V_{rms}$	Flatness for +20dB, Linear Phase Filter
38 <sup>[a]</sup>	100 kHz	5.6 $V_{rms}$	Flatness for +20dB, Linear Phase Filter

[a] Constants are stored after completing this setup.

- 3 Using the numeric keypad or knob, adjust the displayed voltage at each setup to match the measured voltage. Select **ENTER VALUE**.
- 4 After performing setup 38:
  - a If your calibration procedures require you to verify the adjustment just made, exit the calibration menu and perform “**Low Frequency Flatness Verification**” on page 71.

- b** If you are making all the adjustments and then verifying the instrument's performance, continue with the next procedure in this chapter.

## 0 dB Range Flatness Adjustments

- 1 Connect the power meter as shown on page 98.
- 2 Use the power meter to measure the output amplitude for each of the setups in the table below.

### NOTE

Setup 39 establishes the power meter reference for all the remaining setups in this table. You must always perform setup 39 before any of the following setups.

Setup	Nominal Signal			
	Frequency	Amplitude		
39 <sup>[a]</sup>	100 kHz	0.28 Vrms	2 dBm	Power Meter Reference for 0dB Range
40 <sup>[a]</sup>	200 kHz	0.28 Vrms	2 dBm	Flatness for 0 dB, Elliptical Filter
41 <sup>[a]</sup>	500 kHz	0.28 Vrms	2 dBm	Flatness for 0 dB, Elliptical Filter
42 <sup>[a]</sup>	1.5 MHz	0.28 Vrms	2 dBm	Flatness for 0 dB, Elliptical Filter
43 <sup>[a]</sup>	3 MHz	0.28 Vrms	2 dBm	Flatness for 0 dB, Elliptical Filter
44 <sup>[a]</sup>	4 MHz	0.28 Vrms	2 dBm	Flatness for 0 dB, Elliptical Filter
45 <sup>[a]</sup>	6 MHz	0.28 Vrms	2 dBm	Flatness for 0 dB, Elliptical Filter
46 <sup>[a]</sup>	8 MHz	0.28 Vrms	2 dBm	Flatness for 0 dB, Elliptical Filter
47 <sup>[a]</sup>	9.9 MHz	0.28 Vrms	2 dBm	Flatness for 0 dB, Elliptical Filter
48 <sup>[a]</sup>	200 kHz	0.28 Vrms	2 dBm	Flatness for 0 dB, Linear Phase Filter
49 <sup>[a]</sup>	500 kHz	0.28 Vrms	2 dBm	Flatness for 0 dB, Linear Phase Filter
50 <sup>[a]</sup>	1.5 MHz	0.28 Vrms	2 dBm	Flatness for 0 dB, Linear Phase Filter
51 <sup>[a]</sup>	3.0 MHz	0.28 Vrms	2 dBm	Flatness for 0 dB, Linear Phase Filter
52				Setup not used for this instrument
53				Setup not used for this instrument

[a] Constants are stored after completing this setup.



**NOTE**

Setups 52 and 53 (previous page) are not used in this instrument. From the front panel, press the Enter softkey to advance the setup from 52 to 53. No number entry is required.

---

- 3 Using the numeric keypad, adjust the displayed amplitude at each setup to match the measured amplitude (in dBm). Then select **ENTER VALUE**.

**NOTE**

In order to get dBm you must use the numeric keypad (not the knob) to enter the number, and then select “dBm”.

---

- 4 After performing setup 51:
  - a If your calibration procedures require you to verify the adjustment just made, exit the calibration menu and perform “0 dB Range Flatness Verification” on page 72.
  - b If you are making all the adjustments and then verifying the instrument’s performance, continue with the next procedure in this chapter.

## +10 dB Range Flatness Adjustments

**NOTE**

The Linear Phase path is not adjusted. It is approximated using the other path's values.

- 1 Connect the power meter as shown below.

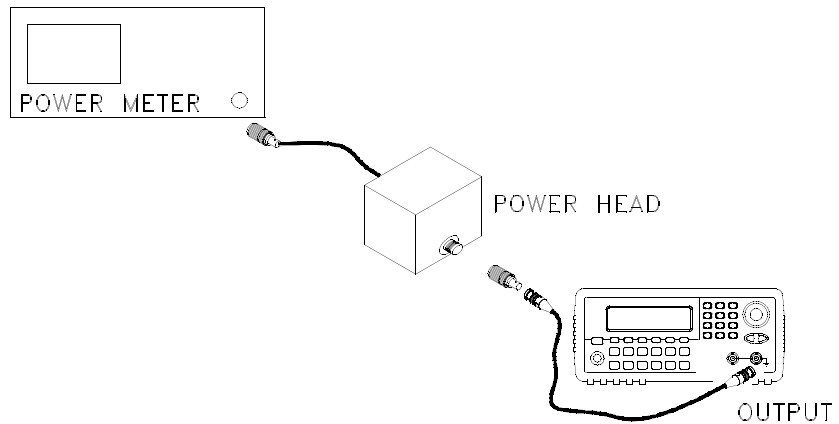

- 2 Use a power meter to measure the output amplitude for each of the setups in the table on the next page.

**NOTE**

Setup 54 establishes the power meter reference for all the remaining setups in this table. You must always perform setup 54 before any of the following setups.

Setup	Nominal Signal			
	Frequency	Amplitude		
54 <sup>[a]</sup>	100 kHz	0.9 Vrms	12 dBm	Flatness for 10 dB, Elliptical Filter
55 <sup>[a]</sup>	200 kHz	0.9 Vrms	12 dBm	Flatness for 10 dB, Elliptical Filter

Setup	Nominal Signal			
	Frequency	Amplitude		
56 <sup>[a]</sup>	500 kHz	0.9 Vrms	12 dBm	Flatness for 10 dB, Elliptical Filter
57 <sup>[a]</sup>	1.5 MHz	0.9 Vrms	12 dBm	Flatness for 10 dB, Elliptical Filter
58 <sup>[a]</sup>	3.0 MHz	0.9 Vrms	12 dBm	Flatness for 10 dB, Elliptical Filter
59	4.0 MHz	0.9 Vrms	12 dBm	Flatness for 10 dB, Elliptical Filter
60 <sup>[a]</sup>	6.0 MHz	0.9 Vrms	12 dBm	Flatness for 10 dB, Elliptical Filter
61 <sup>[a]</sup>	8.0 MHz	0.9 Vrms	12 dBm	Flatness for 10 dB, Elliptical Filter
62 <sup>[a]</sup>	9.9 MHz	0.9 Vrms	12 dBm	Flatness for 10 dB, Elliptical Filter

[a] Constants are stored after completing this setup.

- 3 Using the numeric keypad, adjust the displayed amplitude at each setup to match the measured amplitude (in dBm). Then select **ENTER VALUE**.

#### NOTE

In order to get dBm you must use the numeric keypad (not the knob) to enter the number, and then select “dBm”.

- 4 After performing setup 62:
  - a If your calibration procedures require you to verify the adjustment just made, exit the calibration menu and perform “+10 dB Range Flatness Verification” on page 74.
  - b If you are making all the adjustments and then verifying the instrument’s performance, continue with the next procedure in this chapter.

## +20 dB Range Flatness Adjustment

### CAUTION

Most power meters will require an attenuator ( $-20$  dB) or special power head to measure the  $+20$  dB output.

Be sure to correct the measurements for the specifications of the attenuator you use. For example, if the nominal attenuator value is  $-20$  dB at the specified frequency, you must add 20 dB to the power meter reading before entering the value.

- 1 Make the connections as shown below:

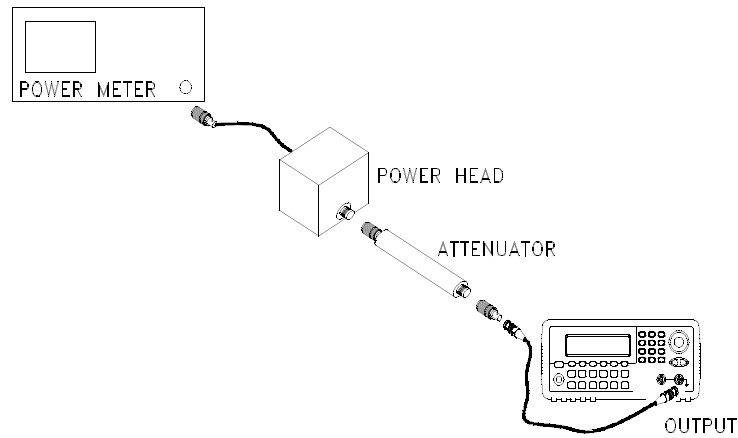

- 2 Use the power meter to measure the output amplitude for each of the setups in the table on the next page.

### NOTE

Setup 63 establishes the power meter reference for all the remaining setups in this table. You must always perform setup 63 before any of the following setups.

Setup	Nominal Signal			
	Frequency	Amplitude		
63 <sup>[a]</sup>	100 kHz	2.8 Vrms	22 dBm	Flatness for 20 dB, Elliptical Filter
64 <sup>[a]</sup>	200 kHz	2.8 Vrms	22 dBm	Flatness for 20 dB, Elliptical Filter
65 <sup>[a]</sup>	500 kHz	2.8 Vrms	22 dBm	Flatness for 20 dB, Elliptical Filter
66 <sup>[a]</sup>	1.5 MHz	2.8 Vrms	22 dBm	Flatness for 20 dB, Elliptical Filter
67 <sup>[a]</sup>	3.0 MHz	2.8 Vrms	22 dBm	Flatness for 20 dB, Elliptical Filter
68 <sup>[a]</sup>	4.0 MHz	2.8 Vrms	22 dBm	Flatness for 20 dB, Elliptical Filter
69 <sup>[a]</sup>	6.0 MHz	2.8 Vrms	22 dBm	Flatness for 20 dB, Elliptical Filter
70 <sup>[a]</sup>	8.0 MHz	2.8 Vrms	22 dBm	Flatness for 20 dB, Elliptical Filter
71 <sup>[a]</sup>	9.9 MHz	2.8 Vrms	22 dBm	Flatness for 20 dB, Elliptical Filter
72 <sup>[a]</sup>	200 kHz	2.8 Vrms	22 dBm	Flatness for 20 dB, Linear Phase Filter
73 <sup>[a]</sup>	500 kHz	2.8 Vrms	22 dBm	Flatness for 20 dB, Linear Phase Filter
74 <sup>[a]</sup>	1.5 MHz	2.8 Vrms	22 dBm	Flatness for 20 dB, Linear Phase Filter
75 <sup>[a]</sup>	3.0 MHz	2.8 Vrms	22 dBm	Flatness for 20 dB, Linear Phase Filter

[a] Constants are stored after completing this setup.

- Using the numeric keypad, adjust the displayed amplitude at each setup to match the measured amplitude (in dBm). Then select **ENTER VALUE**.

#### NOTE

In order to get dBm you must use the numeric keypad (not the knob) to enter the number, and then select “dBm”.

- After performing setup 75:

- a** If your calibration procedures require you to verify the adjustment just made, exit the calibration menu and perform “+20 dB Range Flatness Verification” on page 76.
- b** If you are making all the adjustments and then verifying the instrument's performance, verify the output specifications of the instrument using the “Performance Verification Tests” on page 64.

You have now completed the recommended adjustment procedures. Verification of the output specifications is recommended.

## Calibration Errors

The following errors are failures that may occur during a calibration. System error messages are described in the *Keysight 33210A User's Guide*. Self-test error messages are described on page 120 of this document

### **701: Calibration error; security defeated by hardware jumper**

The function generator's calibration security feature has been disabled by temporarily shorting the two "CAL ENABLE" pads on the internal circuit board as described starting on page 79.

### **702: Calibration error; calibration memory is secured**

A calibration cannot be performed when calibration memory is secured. See "[To Unsecure and Secure for Calibration](#)" on page 44 for a procedure to enter the security code from the front panel. Use the **CAL:SEC:STAT ON** command to enter the security code using the remote interface.

### **703: Calibration error; secure code provided was invalid**

Invalid security code specified with the **CAL:SEC:STAT ON** command.

### **706: Calibration error; value out of range**

You have entered a value that was unexpected by the calibration firmware. For example, if a number is expected such a 50.XX ohms, and you enter 10 ohms, that number is outside the expected range of valid inputs.

### **707: Calibration error; signal input is out of range**

Occurs during the ADC Adjustment, setup 6, if the 1 Volt input voltage is too high. May also occur during self-calibration (setup 7), run self-test to diagnose cause of problem.

### **707: Calibration error; cal edge time; rise time cal error**

### **707: Calibration error; cal edge time; fall time cal error**

### **707: Calibration error; cal edge time; default values loaded**

Indicates a failure in the rise-time or fall-time circuitry has prevented calibration. The edge-time was calibrated using default values, limiting accuracy. Service is required to correct the problem and achieve design accuracy for the rise and fall times.

**850: Calibration error; set up is invalid**

You have selected an invalid calibration setup number with the **CAL:SET** command.

**851: Calibration error; set up is out of order**

Certain calibration steps require a specific beginning and ending sequence. You may not enter into the middle of a sequence of calibration steps.



# 5 Block Diagram

Introduction	106
Block Diagram	107
Power Supplies	110

## Introduction

This chapter provides a high-level overview of the instrument's functional block diagram. For more information on servicing the instrument, see [Chapter 6, "Disassembly and Repair"](#).

- [Block Diagram](#) *on page 107*
- [Power Supplies](#) *on page 110*

## Block Diagram

The function generator's circuits may be divided into three main categories: power supplies, analog circuits, and digital circuits. The instrument is further divided into floating and earth referenced circuitry.

This discussion refers to the block diagram on page page 110.

The Main Processor combines many instrument functions onto one custom IC. It interfaces directly with the GPIB and LAN interfaces, and through a controller chip with the USB interface. A 50 MHz crystal oscillator provides the clock signal for U101 operations. A 24 MHz clock is used for USB operations.

The Main Processor communicates with the Front Panel and performs the keyboard scanning. Serial data is used to write to the display. The cross-isolation communication with the Synthesis IC uses optically isolated serial data links.

The Synthesis IC is a gate array and performs most of instrument functions. This gate array has an on-board UART. A 50 MHz voltage-controlled-oscillator provides the main clock for the Synthesis IC and the Waveform DAC. The Synthesis IC implements clock generation, pulse generation, DDS and modulation functions, and sets the output waveform and function.

The system DAC outputs various control voltages that are multiplexed into track and hold circuits. These output voltages are used to correct the output waveform for various offsets, rise times, and calibration values. If present, the optional external timebase circuitry provides an input and output for an external time base. A Sync Out signal is available at the front panel.

Some of the output voltages are read back to the Synthesis IC via the System ADC. Here, voltages from various circuits in the instrument are multiplexed with the Modulation IN signal and measured by the Synthesis IC.

The 14-bit waveform DAC is loaded with data from the Synthesis IC. The output is then fed through one of two filters before being buffered and sent to the Main Output Circuitry. The two filters are:

- A 9<sup>th</sup> order elliptical filter with a cutoff frequency of 23.5 MHz. This filter includes  $\sin(x)/x$  correction. This filter is used for continuous sine and squarewaves.
- A 7<sup>th</sup> order linear phase filter with a cutoff frequency of 12.5 MHz. This filter is used for ramp, noise, and arbitrary waveforms.

## 5 Block Diagram

A portion of the output sine wave is squared by a comparator and used to create a variable duty cycle signal used by the Synthesis IC to create the squarewave, pulse generator clock, and sync signals.

The squarewave DAC output is split into two opposite value signals and applied to a multiplexer. The output of this multiplexer is a square wave or pulse signal with the correct duty cycle. The rising edge and falling edge of the signal are adjusted and the signal is buffered and sent to the Main Output Circuit.

The Main Output circuit accepts one of two inputs; the sine/arb waveform or the squarewave/pulse waveform. Once selected, the signal can be applied to one or both attenuators and/or a +20 dB amplifier. The attenuators and amplifier are used to create the requested output signal amplitude.

Amplitude Range (V <sub>pp</sub> into 50 Ω)	Offset <2.5 V			Offset >2.5 V		
	-10 dB	-20 dB	Amp	-10 dB	-20dB	Amp
10 V to 3.16 V	Out	Out	In	Out	Out	In
3.16 V to 1 V	In	Out	In	In	Out	In
1 V to 0.316 V	Out	Out	Out	Out	In	In
0.316 V to 0.1 V	In	Out	Out	In	In	In
0.1 V to 0.0316 V	Out	In	Out			
0.0316 to 0.01 V	In	In	Out			

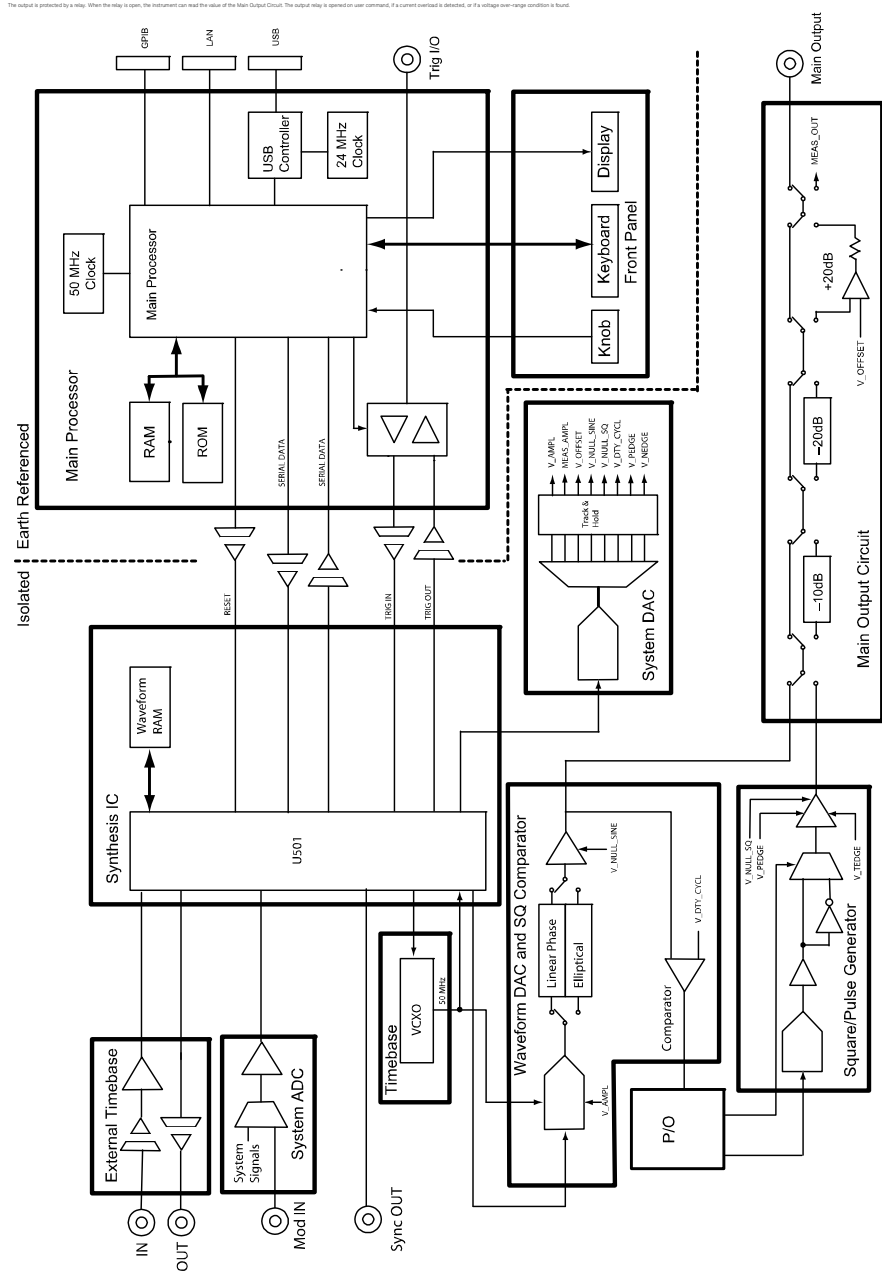

## Power Supplies

The line input voltage is filtered and applied to the main power supply. The main power supply provides all power to the instrument. Secondary power supplies are contained on the main circuit board. The secondary power supplies include both isolated and earth-referenced supplies.

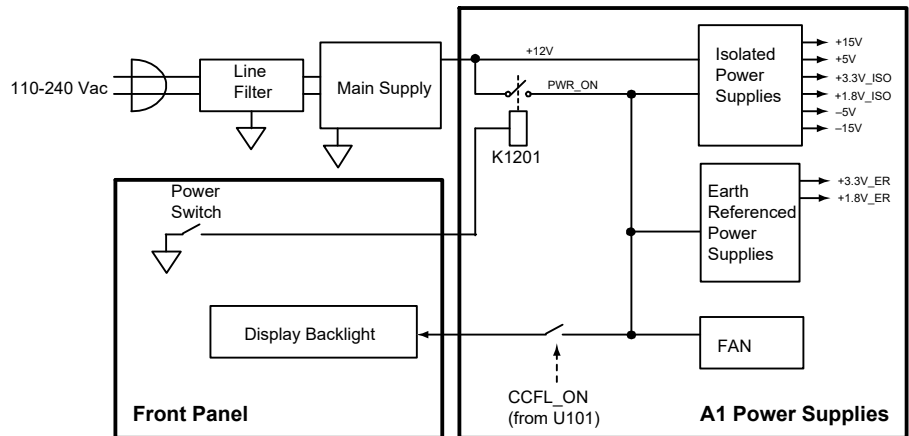

## 6 Disassembly and Repair

Service	112
Operating Checklist	113
Types of Service Available	114
Repackaging for Shipment	115
Cleaning	115
Electrostatic Discharge (ESD) Precautions	116
Surface Mount Repair	116
Troubleshooting Hints	117
Self-Test Procedures	119
Mechanical Disassembly	122
Replaceable Parts	135

## Service

This chapter discusses the procedures involved for returning a failed instrument to Keysight Technologies for service or repair. Subjects covered include the following:

- [Operating Checklist](#) on page 113
- [Types of Service Available](#) on page 114
- [Repackaging for Shipment](#) on page 115
- [Cleaning](#) on page 115
- [Electrostatic Discharge \(ESD\) Precautions](#) on page 116
- [Surface Mount Repair](#) on page 116
- [Troubleshooting Hints](#) on page 117
- [Self-Test Procedures](#) on page 119
- [Mechanical Disassembly](#) on page 122
- [Replaceable Parts](#) on page 135



## Operating Checklist

Before returning your instrument to Keysight Technologies for service or repair, check the following items:

### Is the instrument inoperative?

- Verify that the ac power cord is connected to the instrument.
- Verify that the front-panel On/Standby switch has been pushed.

### Is the display working?

- If the display appears blank, but front-panel keys are lit (and the fan is working), the display screen saver may be enabled. Press any key to restore the display.
- If the display appears blank, but front-panel keys are lit (and the fan is working), the display contrast setting may be too low. Use the  menu to set the display contrast.

### Does the instrument fail self-test?

Remove all external connections to the instrument. Errors may be induced by signals present on the external wiring during a self-test. Long test leads, even leads that are otherwise unconnected, can act as an antenna causing pick-up of ac signals.

## Types of Service Available

If your instrument fails during the warranty period, Keysight Technologies will repair or replace it under the terms of your warranty. After your warranty expires, Keysight offers repair services at competitive prices.

### Extended Service Contracts

Many Keysight products are available with optional service contracts that extend the *covered period* after the standard warranty expires. If you have such a service contract and your instrument fails during the covered period, Keysight Technologies will repair or replace it in accordance with the contract.

### Obtaining Repair Service (Worldwide)

To obtain service for your instrument (in-warranty, under service contract, or post-warranty), contact your nearest Keysight Technologies Service Center. They will arrange to have your unit repaired or replaced, and can provide warranty or repair-cost information where applicable.

To obtain warranty, service, or technical support information you can contact Keysight Technologies at one of the following telephone numbers:

In the United States: (800) 829-4444

In Europe: 31 20 547 2111

In Japan: 0120-421-345

Or use our Web link for information on contacting Keysight worldwide:

**[www.keysight.com/find/assist](http://www.keysight.com/find/assist)**

Or contact your Keysight Technologies Representative.

Before shipping your instrument, ask the Keysight Technologies Service Center to provide shipping instructions, including what components to ship. Keysight recommends that you retain the original shipping carton for use in such shipments.

## Repackaging for Shipment

If the unit is to be shipped to Keysight for service or repair, be sure to:

- Attach a tag to the unit identifying the owner and indicating the required service or repair. Include the model number and full serial number.
- Place the unit in its original container with appropriate packaging material for shipping.
- Secure the container with strong tape or metal bands.

If the original shipping container is not available, place your unit in a container which will ensure at least 4 inches of compressible packaging material around all sides for the instrument. Use static-free packaging materials to avoid additional damage to your unit.

*Keysight suggests that you always insure shipments.*

## Cleaning

Clean the outside of the instrument with a soft, lint-free, slightly dampened cloth. Do not use detergent. Disassembly is not required or recommended for cleaning.

## Electrostatic Discharge (ESD) Precautions

Almost all electrical components can be damaged by electrostatic discharge (ESD) during handling. Component damage can occur at electrostatic discharge voltages as low as 50 volts.

The following guidelines will help prevent ESD damage when servicing the instrument or any electronic device.

- Disassemble instruments *only* in a static-free work area.
- Use a conductive work area to reduce static charges.
- Use a conductive wrist strap to reduce static charge accumulation.
- Minimize handling.
- Keep replacement parts in original static-free packaging.
- Remove all plastic, foam, vinyl, paper, and other static-generating materials from the immediate work area.
- Use *only* anti-static solder suckers.

## Surface Mount Repair

Surface mount components should only be removed using soldering irons or desoldering stations expressly designed for surface mount components. Use of conventional solder removal equipment will almost always result in permanent damage to the printed circuit board and will void your Keysight Technologies factory warranty.

## Troubleshooting Hints

This section provides a brief check list of common failures. Before troubleshooting or repairing the instrument, make sure the failure is in the instrument rather than any external connections. Also make sure that the instrument is accurately calibrated within the last year (see “*Calibration Interval*” on page 58). The instrument’s circuits allow troubleshooting and repair with basic equipment such as a 6½ digit multimeter.

### Unit is Inoperative

- Verify that the ac power cord is connected to the instrument.
- Verify that the front-panel On/Standby switch has been pushed.

### Is the display working?

- If the display appears blank, but front-panel keys are lit (and the fan is working), the display screen saver may be enabled. Press any key to restore the display.
- If the display appears blank, but front-panel keys are lit (and the fan is working), the display contrast setting may be too low. Use the  menu to set the display contrast.

### Unit Fails Self-Test

Ensure that all terminal connections (both front panel and rear terminals) are removed while the self-test is performed.

## Power Supply

Verify the main power supply.

### WARNING

**Shock Hazard.** To check the power supplies, remove the instrument cover as described in “**Mechanical Disassembly**” on page 122.

The main power supply provides a +12 Vdc supply to the main circuit board. All other supplies are derived from this supply. This supply is energized at all times while the line power cord is connected.

Power Supply	Minimum	Maximum
+12 V	11.4 V	12.6 V

- Circuit failure can cause heavy supply loads which may pull down the supply output voltage. Disconnect the main supply from the A1 circuit board to test.
- Always check the supply is free of oscillations using an oscilloscope.
- The main power supply provides an input fuse (type UL/IEC127, rated 250VAC H 3.15A) to protect against the danger of fire in the event of a failure of the power supply circuitry. However, this fuse will not fail ("open" or "blow") in normal power supply operation. The fuse fails only in the event of a significant overload indicating a failure of the power supply circuitry. **Replace the entire main power supply assembly if the input fuse fails.** Note that a power supply failure may be caused by a failure elsewhere in the instrument.

## Self-Test Procedures

### Power-On Self-Test

Each time the instrument is powered on, a small set of self-tests are performed. These tests check that the minimum set of logic and output hardware are functioning properly. In addition to some basic checks, the power-on self test consists of tests 601 through 632.

### Complete Self-Test

To perform a complete self-test:

- 1 Press **Utility** on the front panel.
- 2 Select the **Self Test** softkey from the “Test / Cal” menu.

A complete description of the self-tests is given in the next section.

The instrument will automatically perform the complete self-test procedure when you release the key. The self-test will complete in approximately 30 seconds.

- If the self-test is successful, “Self Test Pass” is displayed on the front panel.
- If the self-test fails, “Self Test Fail” and an error number are displayed.

## Self-Tests

A complete self-test performs the following tests. A failing test is indicated by the test number and description in the display.

**601: Self-test failed; system logic**

This error indicates a failure of the main processor, system RAM, or system ROM.

**603: Self-test failed; waveform logic**

This error indicates that the waveform logic in the synthesis IC has failed.

**604: Self-test failed; waveform memory bank**

This error indicates either the waveform RAM or the synthesis IC has failed.

**605: Self-test failed; modulation memory bank**

This error indicates the modulation memory bank in the synthesis IC has failed.

**606: Self-test failed; cross-isolation interface**

This error indicates that the cross-isolation interface between the main processor and Synthesis IC has failed, or that the synthesis IC itself has failed.

**619: Self-test failed; leading edge DAC**

**620: Self-test failed; trailing edge DAC**

**621: Self-test failed; square-wave threshold DAC**

**623: Self-test failed; dc offset DAC**

**624: Self-test failed; null DAC**

**625: Self-test failed; amplitude DAC**

These errors indicate a malfunctioning system DAC, or failed DAC multiplexer channels.

**622: Self-test failed; time base calibration DAC**

This error indicates that the time base calibration DAC in the synthesis IC, or voltage controlled oscillator has failed.

**626: Self-test failed; waveform filter path select relay**

**627: Self-test failed; -10 dB attenuator path**



**628: Self-test failed; -20 dB attenuator path****629: Self-test failed; +20 dB amplifier path**

These errors indicate that the specified relay is not being properly switched or the attenuator/amplifier is not providing the expected amplification or gain. These self-tests use the internal ADC to verify that attenuators are operating properly.

**630: Self-test failed; internal ADC over-range condition**

This error indicates a probable ADC failure. The failure could be of the system ADC, the ADC input multiplexer, or the ADC input buffer amplifier.

**631: Self-test failed; internal ADC measurement error**

This error indicates a probable ADC failure. The failure could be of the system ADC, the ADC input multiplexer, or the ADC input buffer amplifier.

**632: Self-test failed; square/pulse DAC test failure**

This error indicates a probable failure of the square/pulse DAC.

## Mechanical Disassembly

For procedures in this manual, the following tools are required for disassembly:

- T20 Torx driver (most disassembly)
- T15 Torx driver (support plate and fan removal)
- $\frac{9}{16}$ -inch or adjustable open-end wrench (rear-panel BNC connectors)

The following tools may also be needed if further disassembly is required.

- 7 mm nut driver (rear-panel GPIB connector)

### **WARNING**

**SHOCK HAZARD.** Only service-trained personnel who are aware of the hazards involved should remove the instrument covers. To avoid electrical shock and personal injury, make sure to disconnect the power cord from the instrument before removing the covers. Some circuits are active and have power applied even when the power switch is turned off.

---

## General Disassembly Procedure

- 1 Turn off the power. Remove all cables from the instrument.
- 2 Rotate the handle upright and pull off.

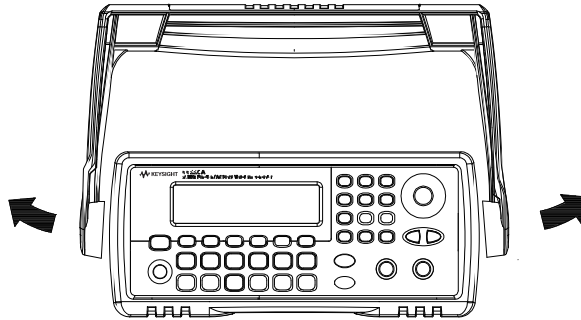

- 3 Pull off the instrument bumpers.

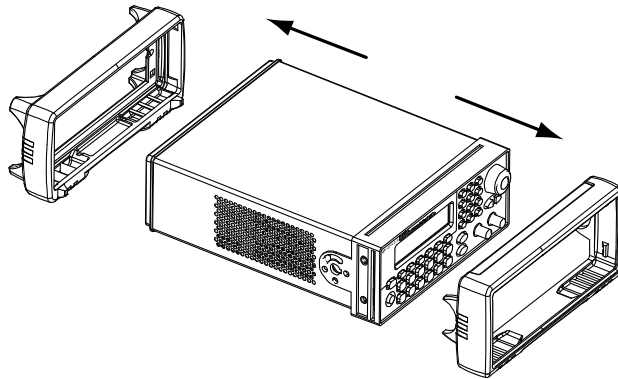

- 4 Loosen the two captive screws in the rear bezel and remove the rear bezel.

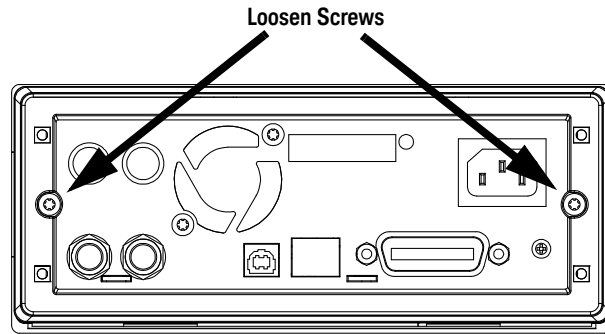

- 5 Slide off the instrument cover.

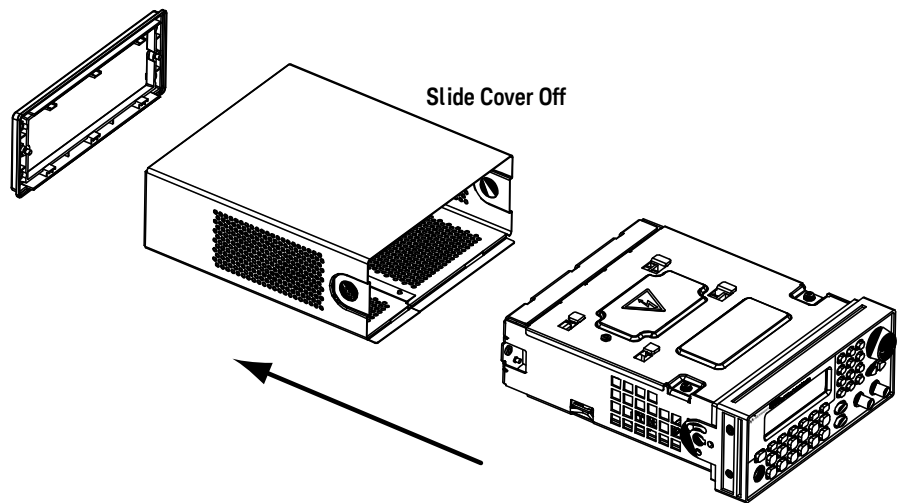

- 6** Remove the two screws securing the power supply deck to the chassis. Lift off the deck. The power supply assembly is attached to the deck.

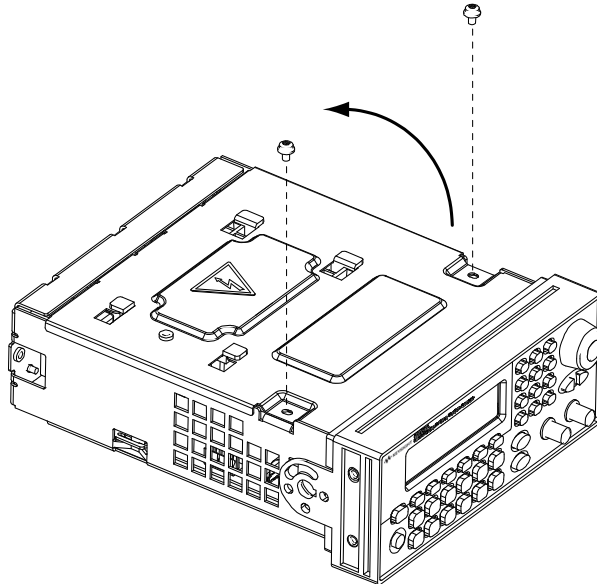

- 7** Lay the deck and power supply assembly to the side.

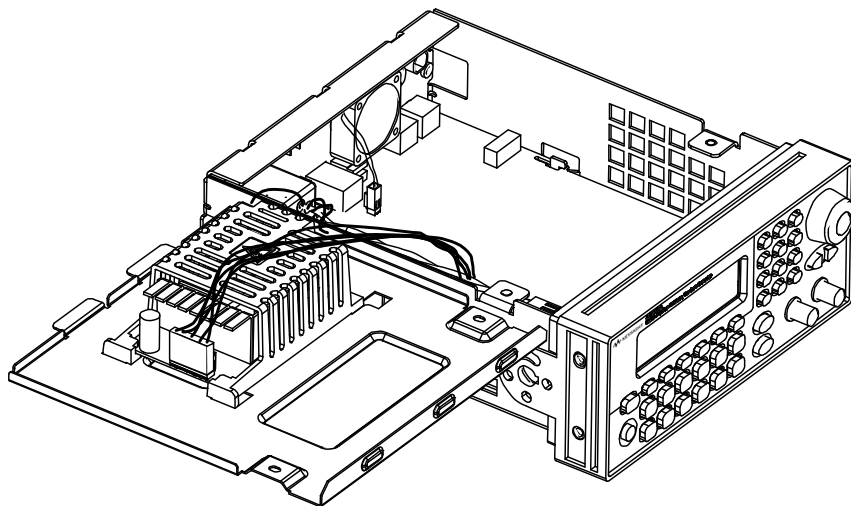

Many of the service procedures can now be performed without further disassembly. Troubleshooting and service procedures that require power be applied can be performed with the instrument in this state of disassembly.

**WARNING**

**SHOCK HAZARD.** Only service-trained personnel who are aware of the hazards involved should remove the instrument covers. Dangerous voltages may be encountered with the instrument covers removed.

---

## Removing the Main Power Supply Assembly

Loosen the captive screw securing the power supply cover to the deck. Slide the power supply cover and power supply and lift from the deck. Slightly spread the ends of the power supply cover and slide the power supply out of the cover. Disconnect the line input, ground, and output cables from the power supply. The main power supply should be replaced as an assembly.

**WARNING**

Always be sure to re-attach the green ground wire to the power supply before operating the instrument.

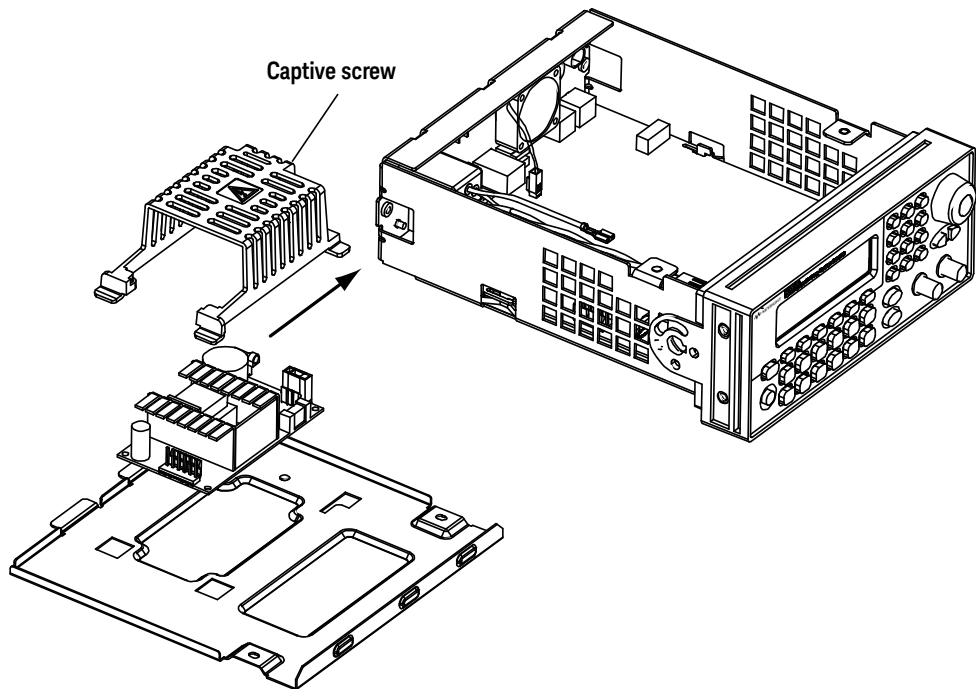

## Front-Panel Removal Procedure

- 1 Gently lift both ends of the flat flex cable connector actuator and disconnect the cable from the main PC board (A1 assembly).

### CAUTION

To prevent damage to the cable and connector, use care when lifting the actuator. Excessive or uneven force may damage the actuator or connector.

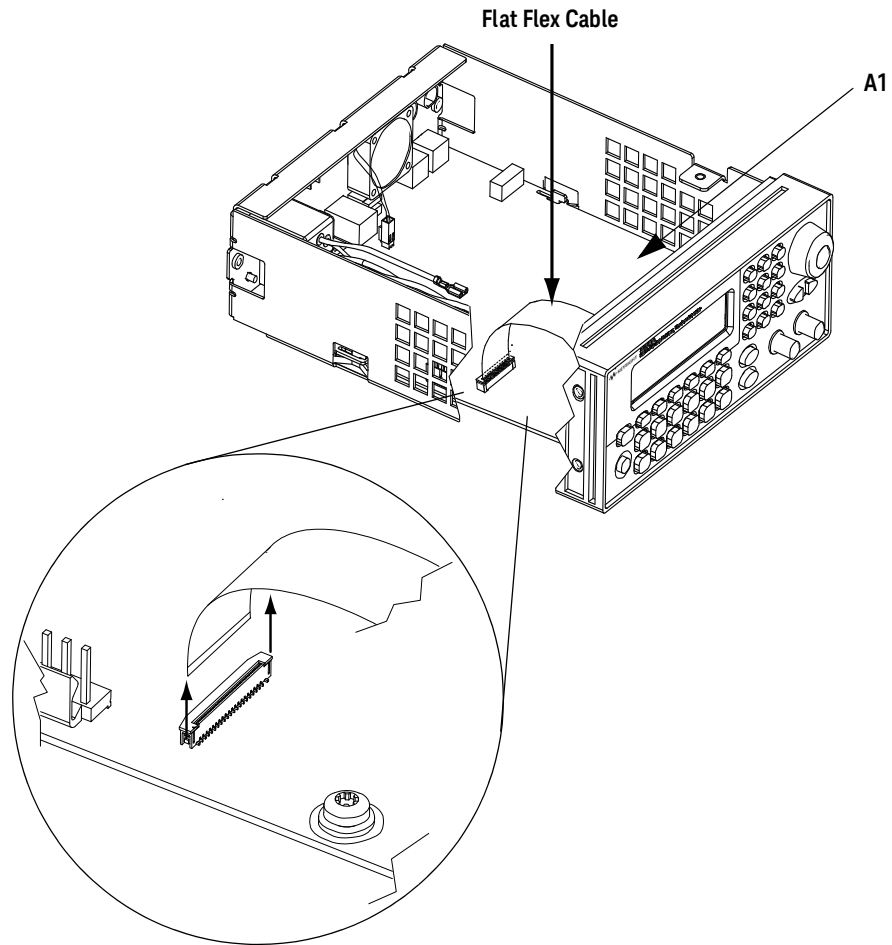



- 2 Remove the two screws from the front edge of the main PC board (A1 assembly).

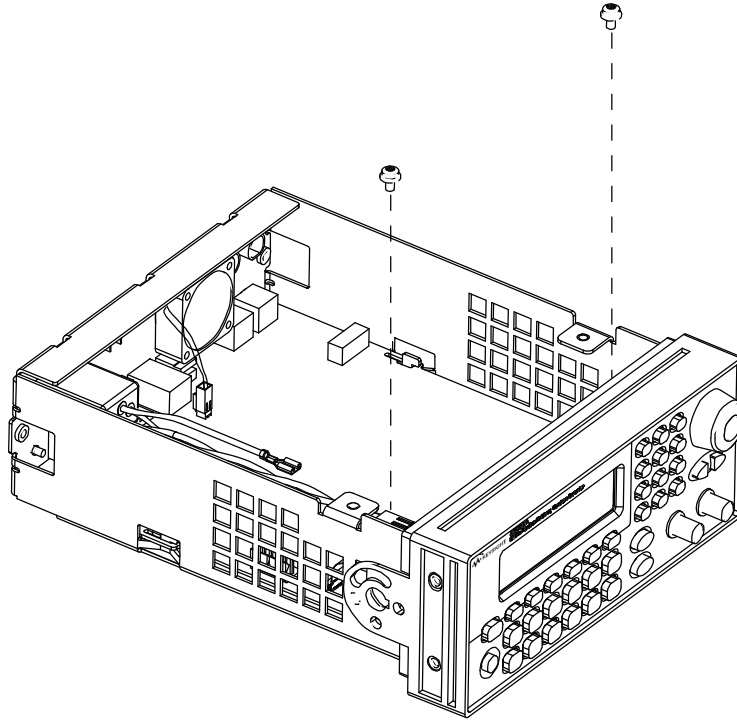

- 3** Push the side flanges of the chassis inward while lifting off the front panel. There should now be enough play in the chassis sides and front panel assembly to allow the side of the front panel to be disconnected from the chassis.

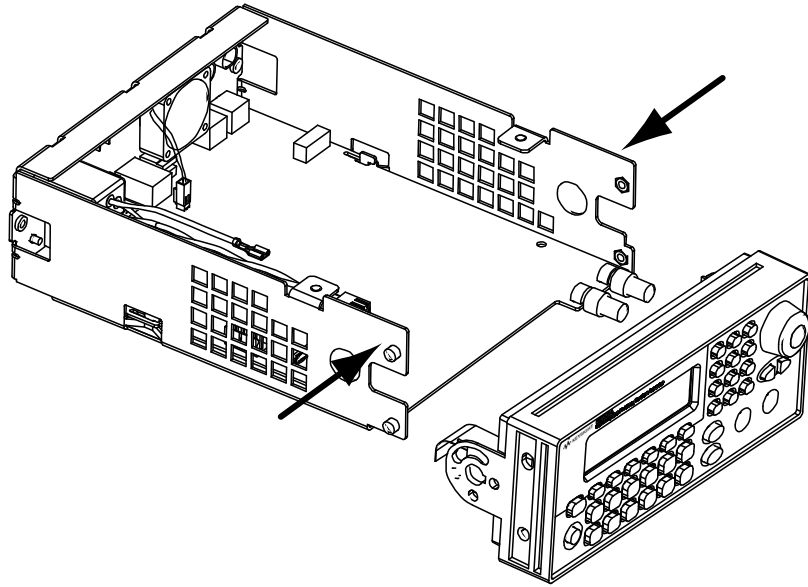

## Front-Panel Disassembly

- 1 Loosen the captive screw holding the support plate. Lift the end of the support plate and rotate out of the front panel assembly.

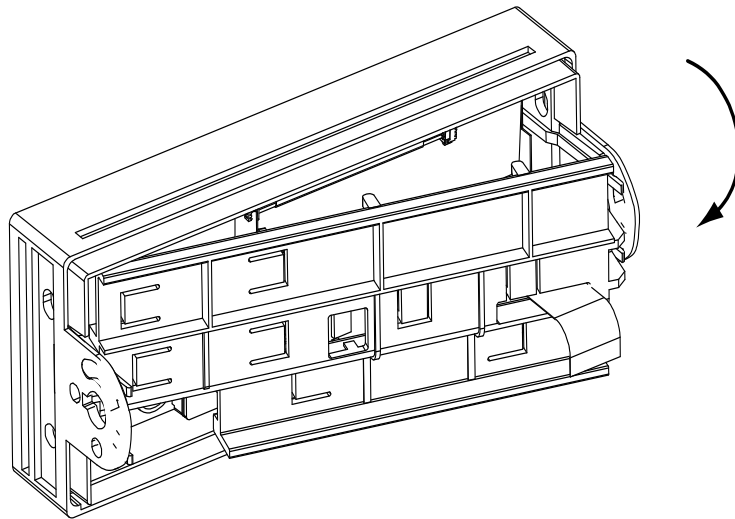
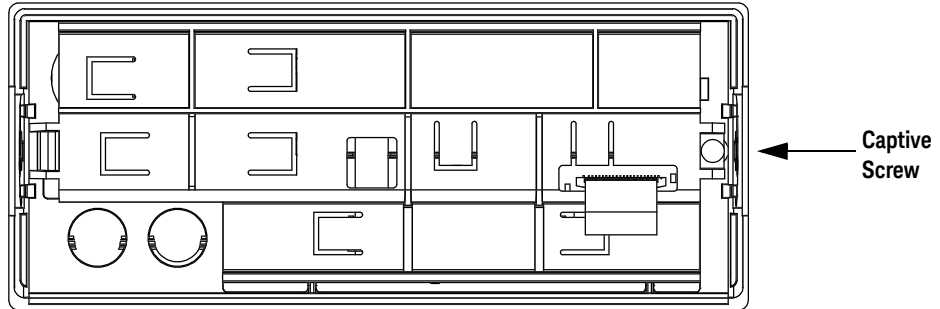

- 2 Unplug the inverter cable from the keyboard PC board (A2 assembly). Gently lift both ends of the flat flex cable connector actuator and disconnect the cable from the PC board. Lift out the display assembly.

**CAUTION**

To prevent damage to the cable and connector, use care when lifting the actuator. Excessive or uneven force may damage the actuator or connector.

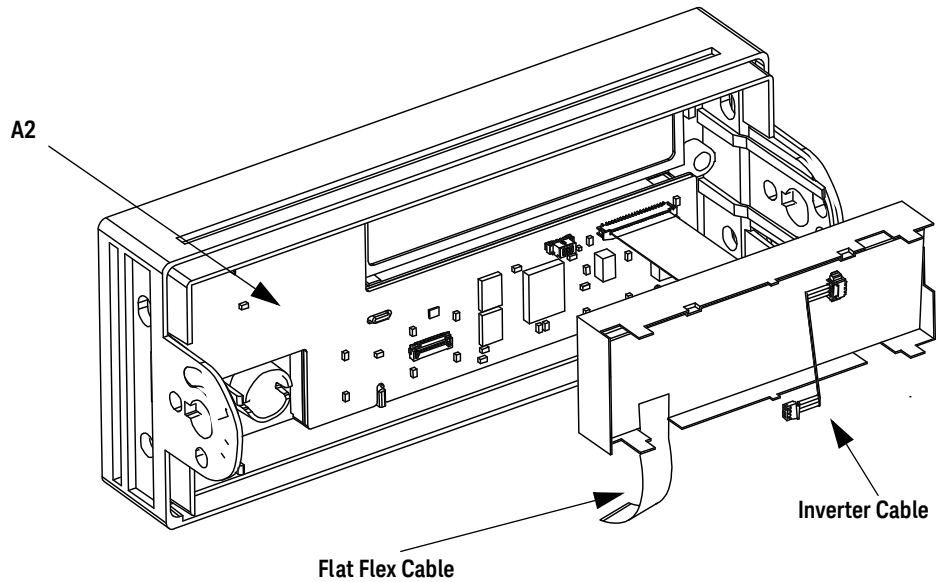

- 3 Pull to remove the knob. Lift out the keyboard PC board (A2 assembly).

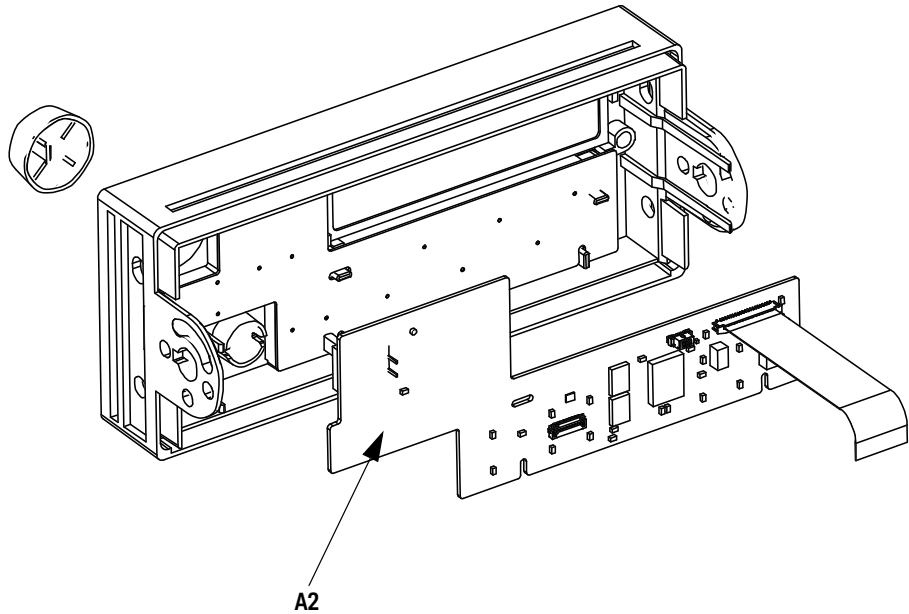

## External Timebase Circuit Board Disassembly

The External Timebase is an option to the basic instrument (Option 001).

Remove the hex nuts and washers holding the rear panel **10 MHz In** and **10 MHz Out** BNC connectors. Pull the External Timebase PC board (A3 assembly) from the back panel as shown below. Then unplug the captive ribbon cable from the keyed connector on the main PC board (J601 on the A1 assembly). Remove the A3 assembly from the chassis.

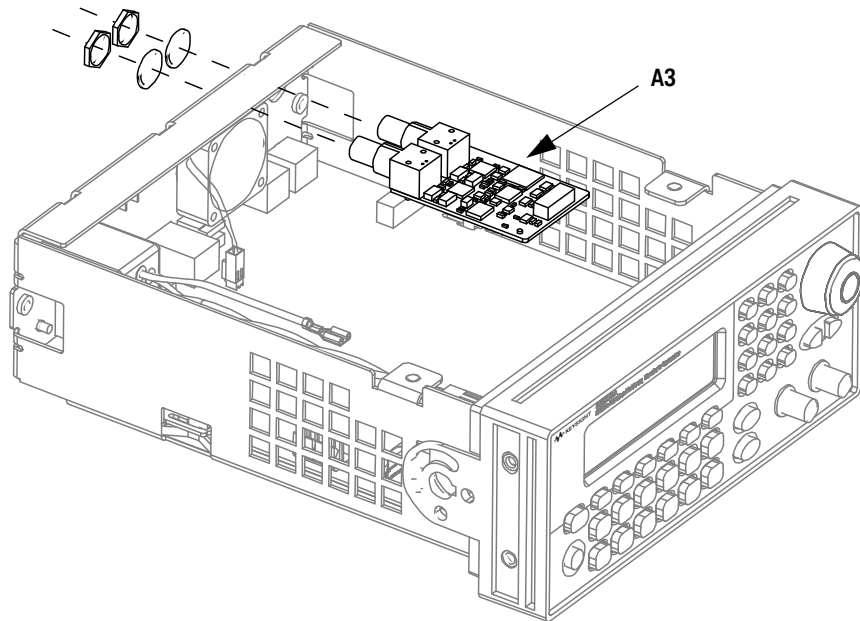

## Replaceable Parts

This section contains information for ordering replacement parts for your instrument. The parts lists are divided into the following sections.

Parts are listed by part number. The replaceable parts lists include a brief description of each part with applicable Keysight part number.

### To Order Replaceable Parts

You can order replaceable parts from Keysight using the Keysight part number. Note that not all parts listed in this chapter are available as field-replaceable parts. To order replaceable parts from Keysight, do the following:

- 1** Contact your nearest Keysight Sales Office or Service Center.
- 2** Identify the parts by the Keysight part number shown in the replaceable parts list.
- 3** Provide the instrument model number and serial number.

### Parts List

Keysight Part Number	Description
0960-2545	Rotary Encoder
1250-2913	MOD IN BNC
1250-3569	Output/Sync BNC
1252-2161	GPIB Connector
1253-5030	LAN Connector
2090-0886	Display
33210-60201	Front Panel
33210-80001	Opt 001 Retrofit Kit
33220-66502	Front Panel PCB
33220-67601	Assembly Line Filter
33220-68501	Fan Assembly

## 6 Disassembly and Repair

Keysight Part Number	Description
33220-84101	Cover
33220-87910	Power Supply Assembly
33220-88304	Rear Bezel
33250-49301	Window
33250-87401	Knob
34401-45021	Handle
34401-86020	Bumper Kit



# 7 Backdating

This chapter normally contains information necessary to adapt this manual to instruments not directly covered by the current content. At this printing, the manual applies to all instruments.

THIS PAGE HAS BEEN INTENTIONALLY LEFT BLANK.

# Index

## A

ac connector, 7  
air flow, 34  
amplitude, 22  
amplitude units  
  converting, 23  
arbitrary waveform  
  front-panel operation, 30  
arbitrary waveforms  
  built-in waveforms, 30

## B

built-in help system, 31  
bumpers, removing, 33

## C

calibration certificate, 19  
carrying handle  
  changing positions, 20  
  removing, 33  
CD-ROM, connectivity  
  software, 19  
chassis ground, 7  
configuration  
  GPIB, 48  
  remote interface, 48  
  USB, 48  
context-sensitive help, 31

## D

dc offset  
  front-panel selection, 24  
dc voltage  
  front-panel selection, 24  
DC volts  
  setting, 26  
DHCP, 50  
display  
  overview, 5  
display, graph mode, 29  
dot notation

  and IP addresses, 53  
  duty cycle  
  front-panel selection, 27

## E

edge time, pulse, 28

## F

frequency  
  front-panel selection, 21  
front panel  
  connectors, 4  
  display overview, 5  
  number entry, 6  
  overview, 4  
front-panel configuration  
  LAN, 49  
front-panel menu  
  quick reference, 37  
front-panel selection, 22

## G

GPIB  
  configuration, 48  
  connector, 7  
graph mode, 29

## H

handle  
  changing positions, 20  
  removing, 33  
help system, 31  
  language selection, 32  
high level  
  setting, 25  
high Z load, 41

## I

IEEE-488  
  connector, 7

impedance, load, 41  
instrument reset, 42  
instrument states  
  naming from front panel, 47  
  storing from front-panel, 47  
IP address, 51  
  dot notation, 53  
  further information, 53

## L

LAN  
  connector, 7  
  front-panel configuration, 49  
  setting address, 49  
language, help system, 32  
LCD display, 5  
load, 41  
load termination, 41  
local language, help, 32  
low level  
  setting, 25

## M

menu  
  quick reference, 37

## N

naming stored states  
  front-panel operation, 47  
number entry, 6  
number keypad, 6  
numeric entry, 6

## O

offset  
  front-panel selection, 24  
output amplitude  
  front-panel selection, 22  
output frequency  
  front-panel selection, 21  
output period

- front-panel selection, 21
- output resistance, 41
- output termination, 41
- overheating, 34
- overview
  - display, 5
  - front panel, 4
  - front-panel menus, 37
  - number entry, 6
  - rear panel, 7

## P

- period
  - front-panel selection, 21
- power connector, 7
- power cord, 19
- power switch, 19
- pulse
  - front-panel configuration, 28
- pulse width, 28

## Q

- quick start, 17

## R

- rack mounting kits, 34
- rear panel
  - connectors, 7
  - overview, 7
- remote interface
  - configuration, 48
- reset, 42
- resistance, load, 41
- rubber bumpers, removing, 33

## S

- screen, 5
- setting address
  - LAN, 49
- shipping contents, 19
- shock hazard, 7
- softkey labels, 5
- software, connectivity, 19
- square wave
  - duty cycle selection, 27

- state storage
  - front-panel operation, 47
  - naming from front panel, 47
- stored states
  - front-panel operation, 47
  - naming from front panel, 47

## T

- temperature overload, 34
- termination, 41
- translated language, help
- system, 32

## U

- units
  - converting voltage, 23
- USB
  - configuration, 48
  - connector, 7

## V

- voltage units
  - converting, 23



This information is subject to change without notice. Always refer to the Keysight website for the latest revision.

© Keysight Technologies 2008 - 2017  
Edition 2, October 1, 2017

Printed in Malaysia



33210-90010

[www.keysight.com](http://www.keysight.com)