

C-RAM HPA

RoHS
Compliant

TECHNICAL BULLETIN 390-11

HIGH PERFORMANCE RF ABSORBER FOR MEDIUM HIGH POWER

C-RAM HPA is a hollow pyramidal RF absorber designed to provide high levels of absorption in high power applications. Typical uses include the hot spots in test rooms or anechoic chambers where heating due to concentrated power might damage conventional materials or lead to danger of smoke and fire. Power densities of up to 2 W/in^2 have been handled successfully. C-RAM HPA is usually used with other products such as C-RAM SFC or C-RAM EVA in an anechoic chamber application.

C-RAM HPA consists of lightweight, hollow pyramids. The pyramids are formed by folding relatively thin sheets of lossy foam plastic into shape and bonding them to a foam back panel. As an option, small vent holes may be bored through the walls of the absorber, allowing forced cooling air to be blown through the piece from behind.

TYPICAL PROPERTIES

The table on the reverse side gives dimensions, weights and reflectivity characteristics of the two grades of C-RAM HFP.

FIRE RETARDANCY

C-RAM HPA meets the fire retardancy requirements of NRL Specification 8093, tests 1, 2, and 3, as well as those of MIT document MS-8-21 tests 1, 2, and 3, and T.I> drawing 2693066.

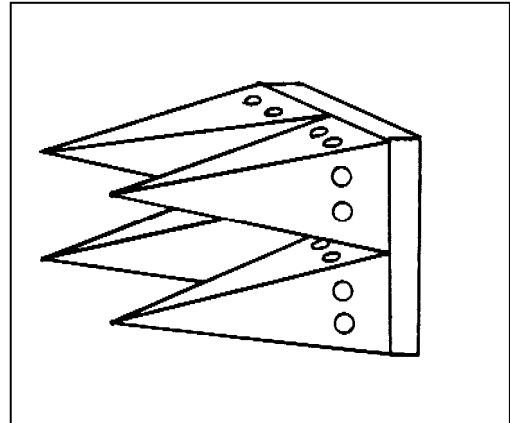

METHOD OF APPLICATION

C-RAM HPA is bonded to walls and ceiling of a test room using polychloroprene adhesive or Velcro fasteners, in the same way as normal C-RAM SFC pieces would be mounted. Details of mechanical mounting schemes can be provided for applications where forced air cooling is required.

Pieces can be readily trimmed with a bandsaw, but cutting pieces to fit should be minimized, as the full structure of the piece is required to support the hollow pyramid.

AVAILABILITY

C-RAM HPA is available in two height grades as given in the table below. Both grades come in a standard 610 x 610 mm (24 inch x 24 inch) base size, and both have four individual pyramids per piece. Depending upon the application and the room dimensions, Cuming Microwave engineers can help you size the proper absorbing material and can advise of methods of using forced air cooling.

TYPICAL PHYSICAL AND REFLECTIVITY CHARACTERISTICS OF C-RAM HPA

GRADE	HEIGHT in. (mm)	WEIGHT Lbs. (kg)	TIPS PER PIECE	Reflectivity in dB at Frequency (GHz)					
				0.03	0.10	0.30	1.0	3.0	10.0+
HPA-36	38 (965)	12 (5.5)	4		-5	-25	-35	-45	-50
HPA-48	50 (1270)	16 (7.3)	4	-5	-10	-30	-45	-50	-50

The information in this technical bulletin, although believed to be accurate, is not to be taken as a warranty for which Cuming Microwave assumes legal responsibility, nor as permission or recommendation to practice any patented invention without license. It is offered for verification by the customer, who must make the final judgment of suitability for any application.